

I **Emulatore Sonda Lambda OBD2 - μ FIX Codice 425**
Schemi d'installazione
Elenco vetture su cui installare l'Emulatore Sonda Lambda OBD2 - μ FIX Codice 425.
L'elenco delle vetture potrà essere aggiornato da A.E.B. in qualsiasi momento.

GB **Lambda Feeler Emulator OBD2 - μ FIX Code 425**
Installation diagrams
List of the cars on which to install the Lambda Feeler Emulator OBD2 - μ FIX Code 425.
The car list can be updated by A.E.B. at any moment.

F **Emulateur Sonde Lambda OBD2 - μ FIX Code 425**
Schémas d'installation
Liste des voitures sur lesquelles installer l'Emulateur Sonde Lambda OBD2 - μ FIX Code 425.
La liste des voitures pourra être actualisée par A.E.B. à tout moment.

E **Emulador Sonda Lambda OBD2 - μ FIX Código 425**
Esquemas de instalación
Lista de los coches sobre los cuales el Emulador Sonda Lambda OBD2 - μ FIX Código 425.
La lista de los coches podrá ser actualizado por A.E.B. en cualquier momento.

P **Emulador Sonda Lambda OBD2 - μ FIX Código 425**
Esquema de instalação
Lista de viaturas sobre as quias instalar o Emulador Sonda Lambda OBD2 - μ FIX Código 425.
A lista das viaturas poderá ser actualizada pela A.E.B. em qualquer momento.

ITALIANO

ENGLISH

FRANCAIS

ESPAÑOL

PORTUGUES

Indice - Index - Table OBD II - μFIX Cod. 425

AUDI	INIEZIONE - INJECTION INYECCION - INJEÇÃO	SCHEMA - DIAGRAM SCHEMA - ESQUEMA ESQUEMA
A2 1.4i 16v	Multipoint MARELLI - AUA	5
A3 1.8i 20v	Multipoint BOSCH - APG	4
SKODA		
Felicia 1.4i	Mpi SIEMENS 5WP44	1
Fabia 1.4i	Mpi SIEMENS 5WP44 - ATZ	1
Fabia 1.4i 16v	Mpi MARELLI IAW 4LVC	5
Octavia 1.6i	Mpi SIEMENS 5WP400 - AVU	4
SUBARU		
Forester 2.0i 16v	Multipoint	4
VOLKSWAGEN		
Polo 1.0i	Mpi BOSCH ME 7.5	4
Polo 1.4i	Multipoint BOSCH - AKK	1
Polo 1.4i 16v	Mpi MARELLI IAW 4LV.KA	2
Golf 1.4i 16v	Multipoint BOSCH	1
Golf 1.6i	Mpi SIEMENS 5WP400 - APF	4
Golf 1.6i 16v	Mpi MARELLI IAW 4LVH - AUS	8
Bora 1.6i 16v	Multipoint MARELLI - AZD	8
Sharan 2.8i V6	Multipoint BOSCH	4
VOLVO		
V70 2.0i 20v Turbo	Mpi BOSCH - B5204T5	4

Indice - Index - Table OBD II - μFIX Cod. 425 + Adapter 349

HONDA	INIEZIONE - INJECTION INYECCION - INJEÇÃO	SCHEMA - DIAGRAM SCHEMA - ESQUEMA ESQUEMA
Accord 2.0i 16v V - Tec	Multipoint - F20B2	3
TOYOTA		
Rav 4 2.0i 16v VVT - i	Multipoint	6
VOLVO		
S60 2.4i 20v	Multipoint DENSO - B5244S	7

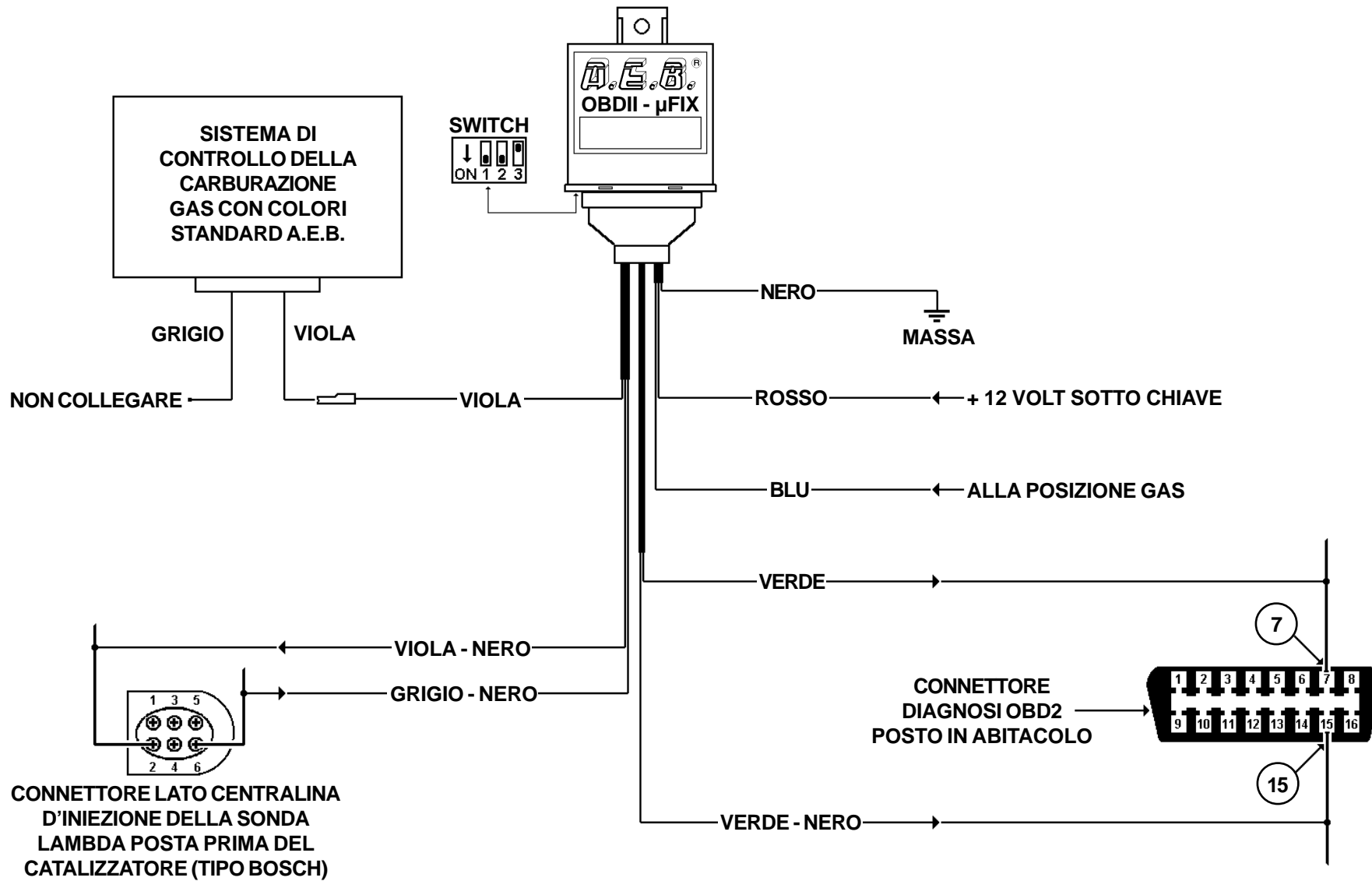

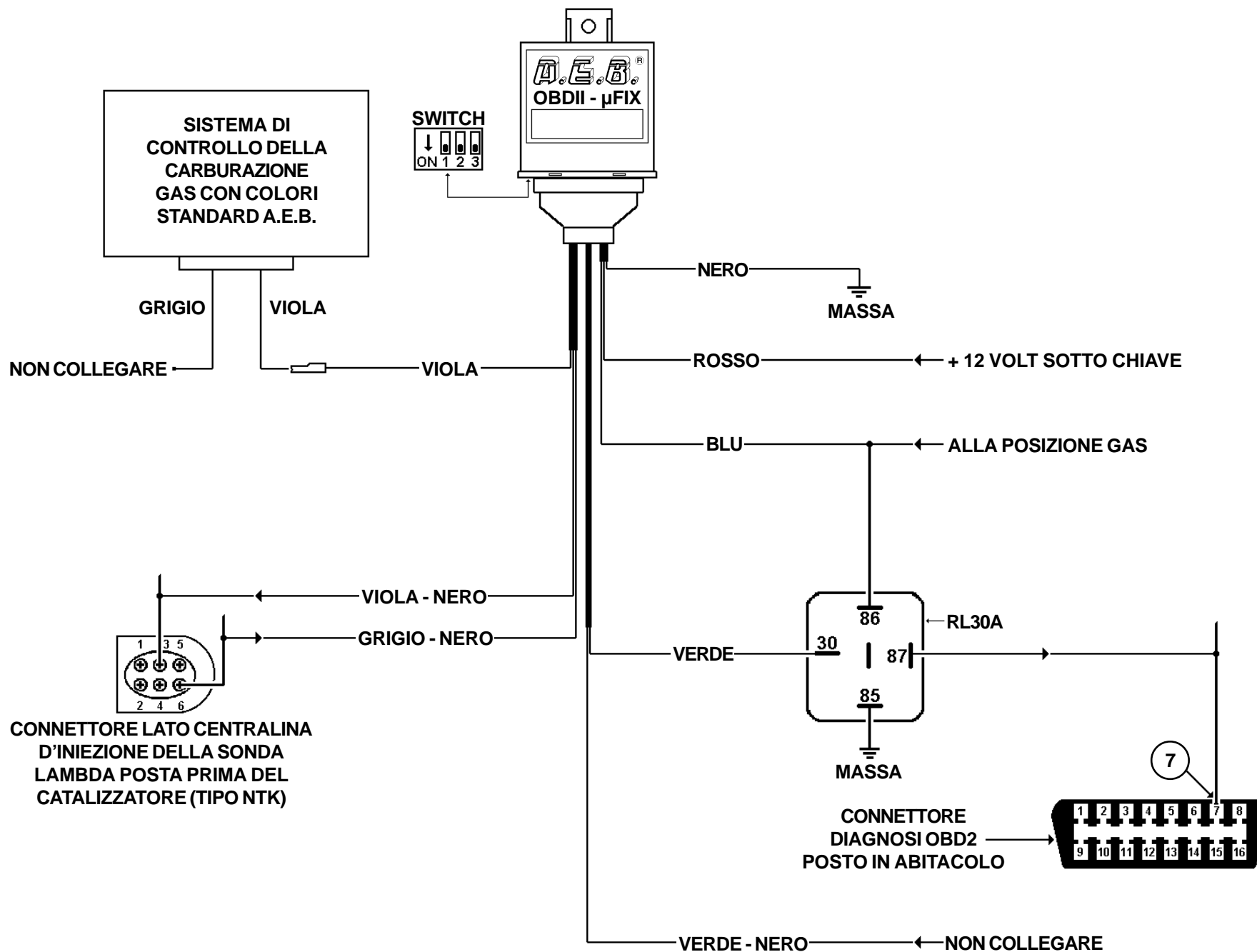

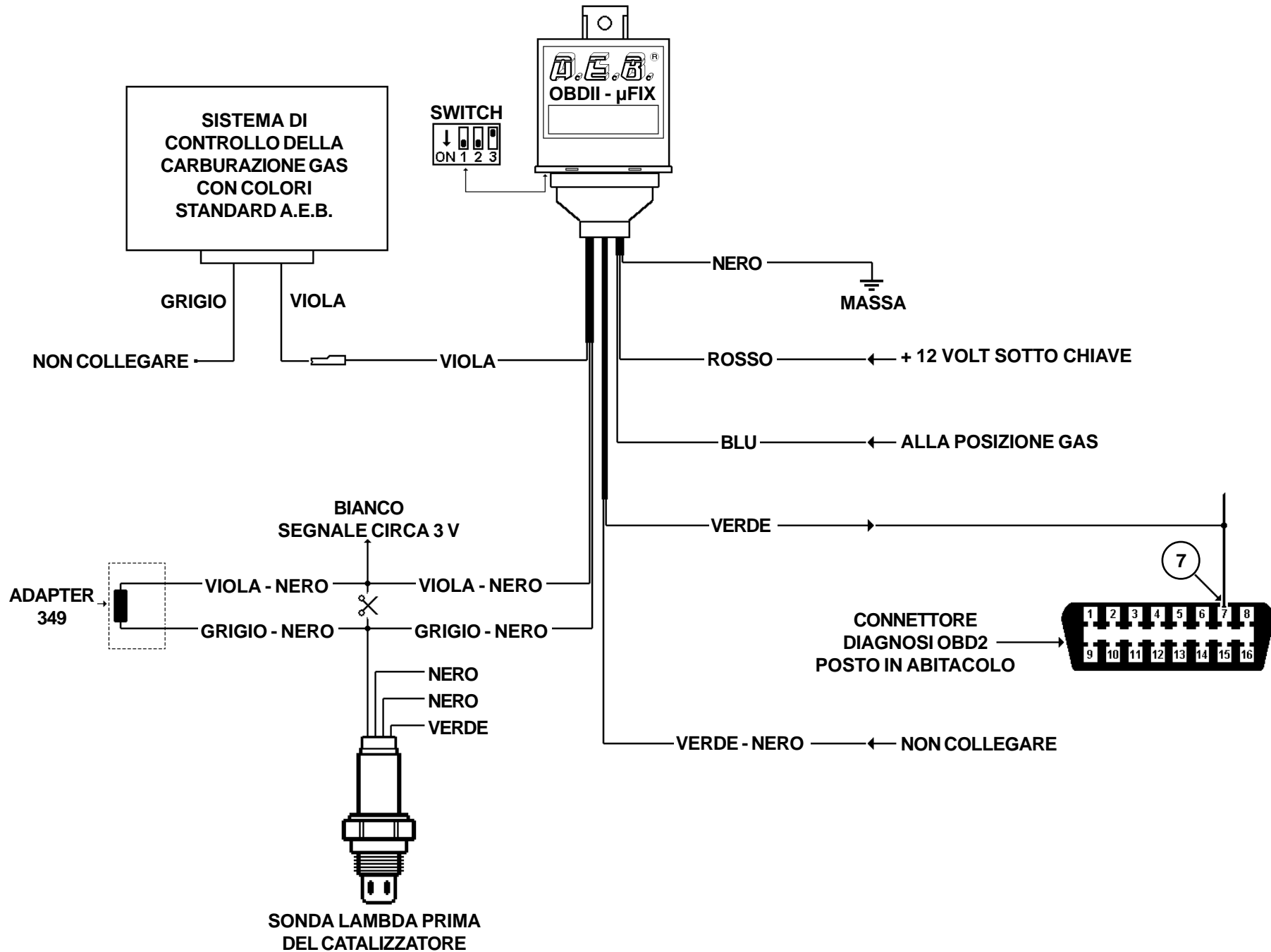

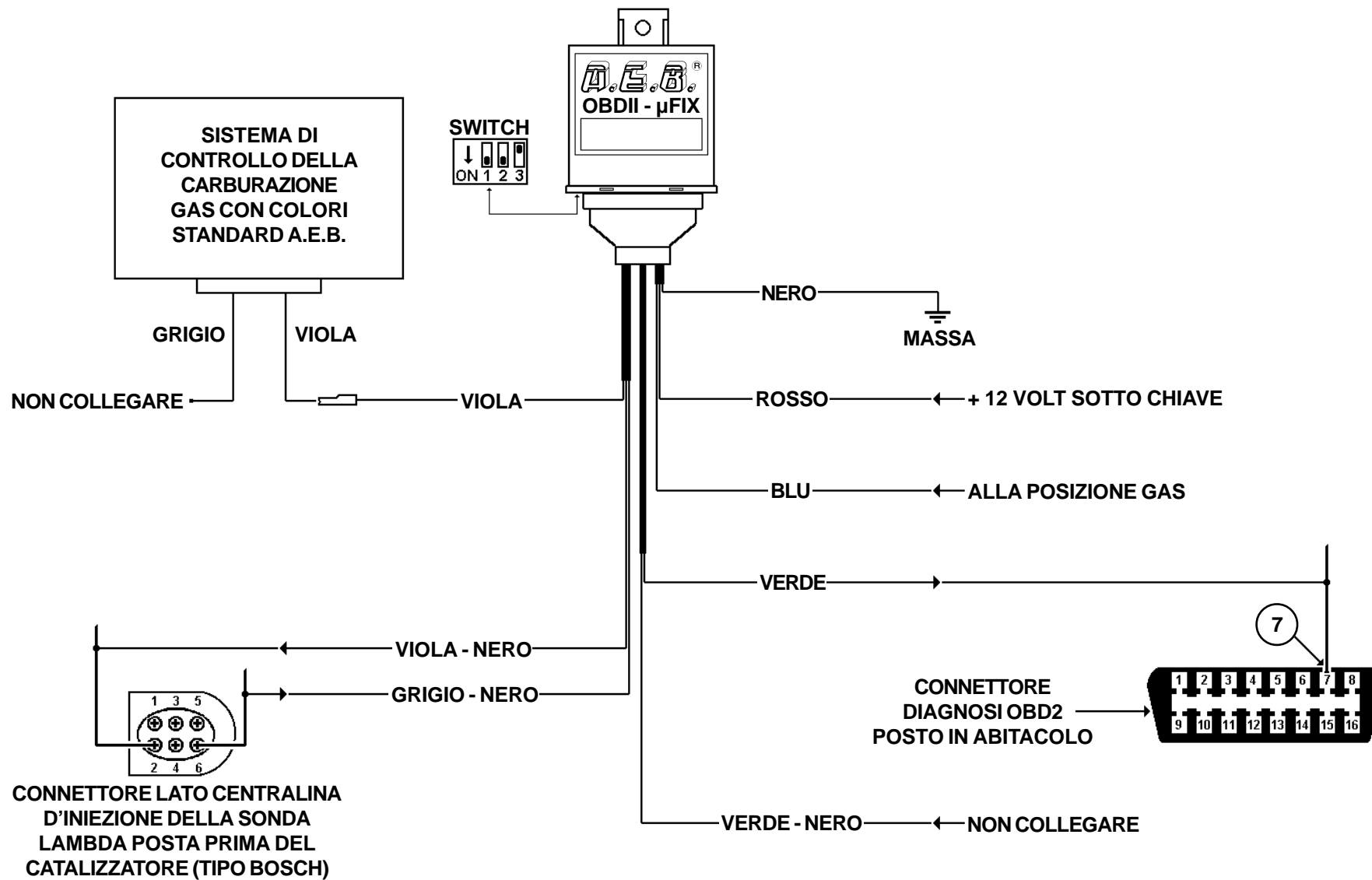

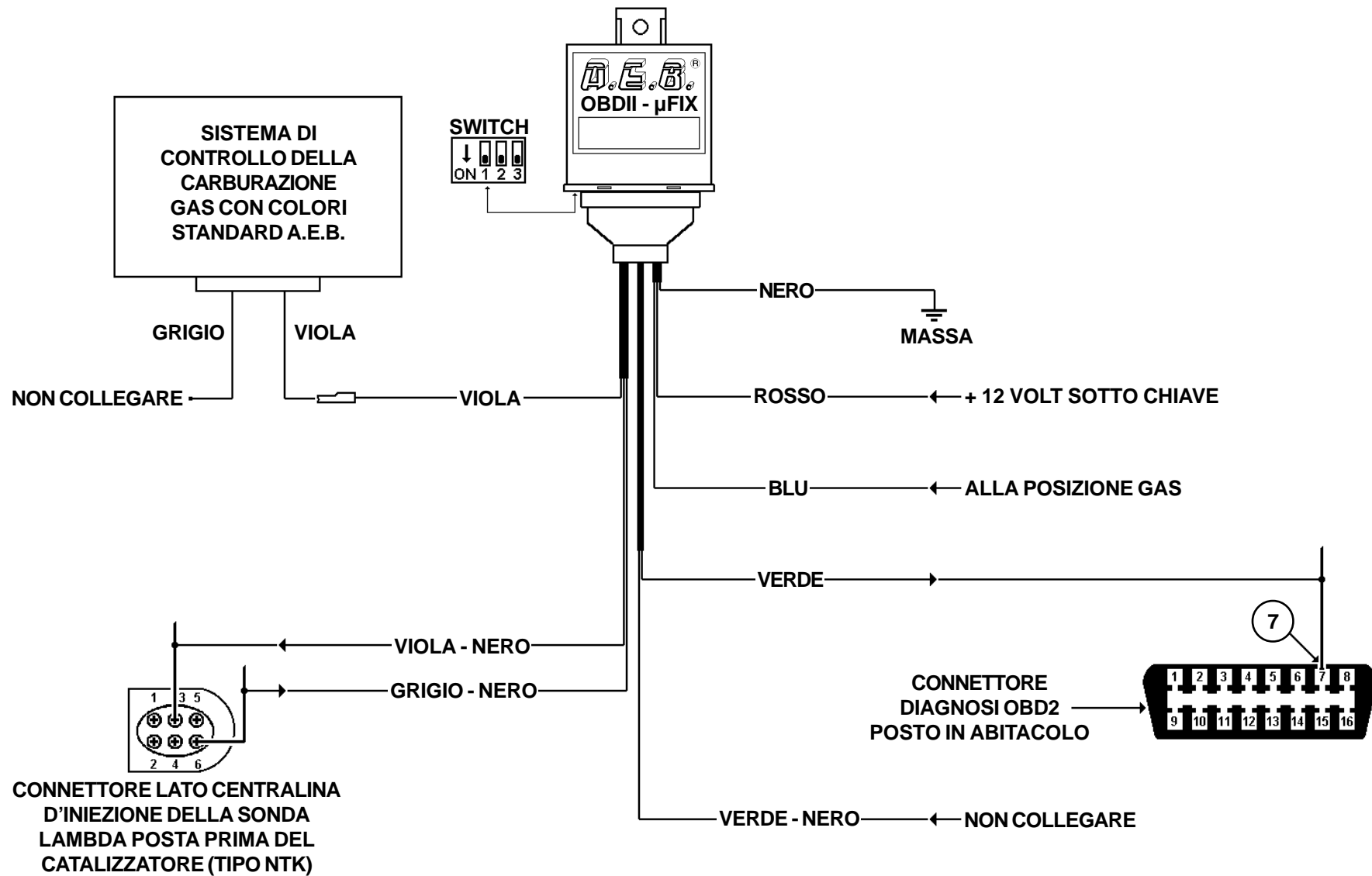

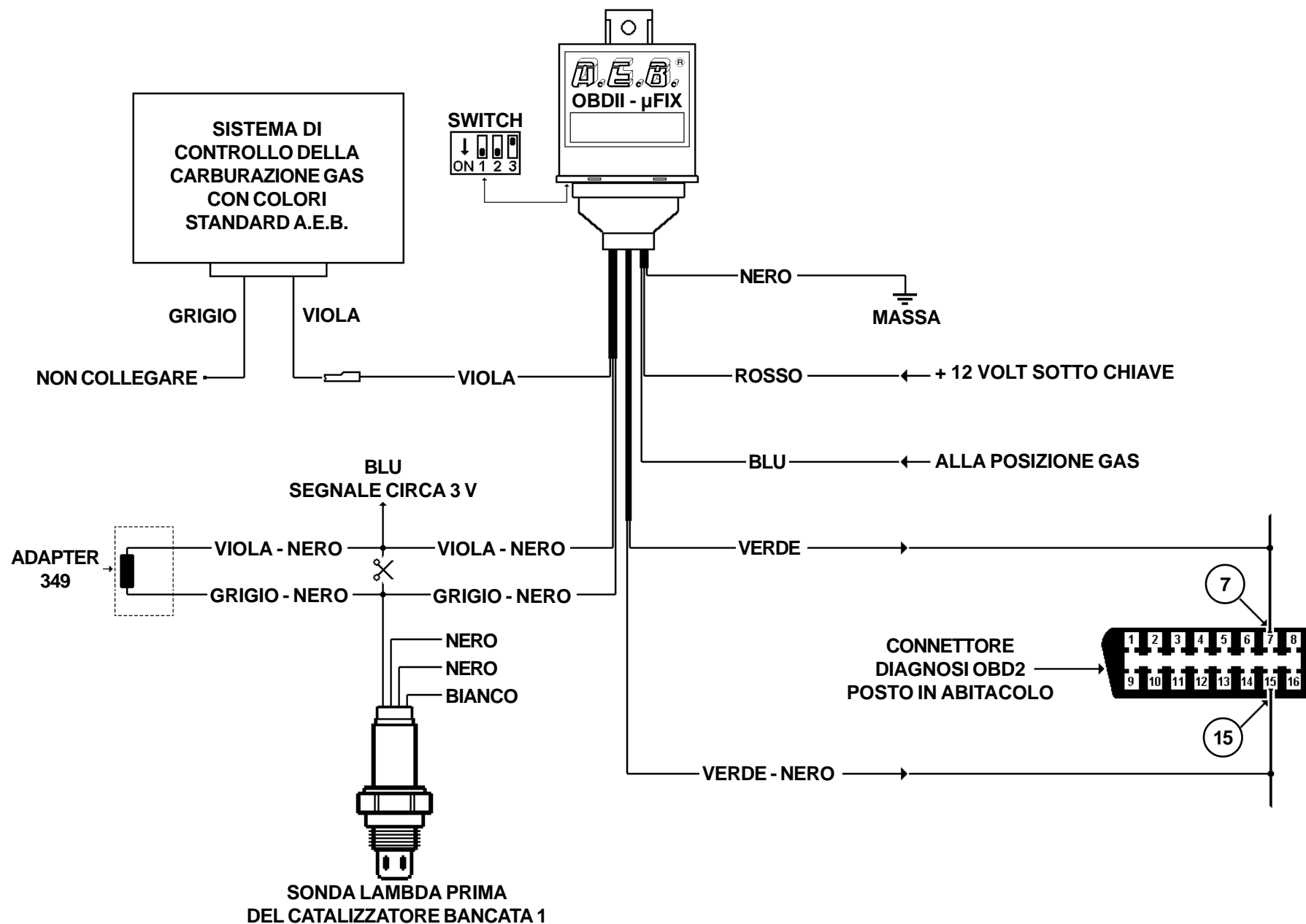

N.B.: LA BANCATA 1 È IN CORRISPONDENZA DEL CILINDRO 1

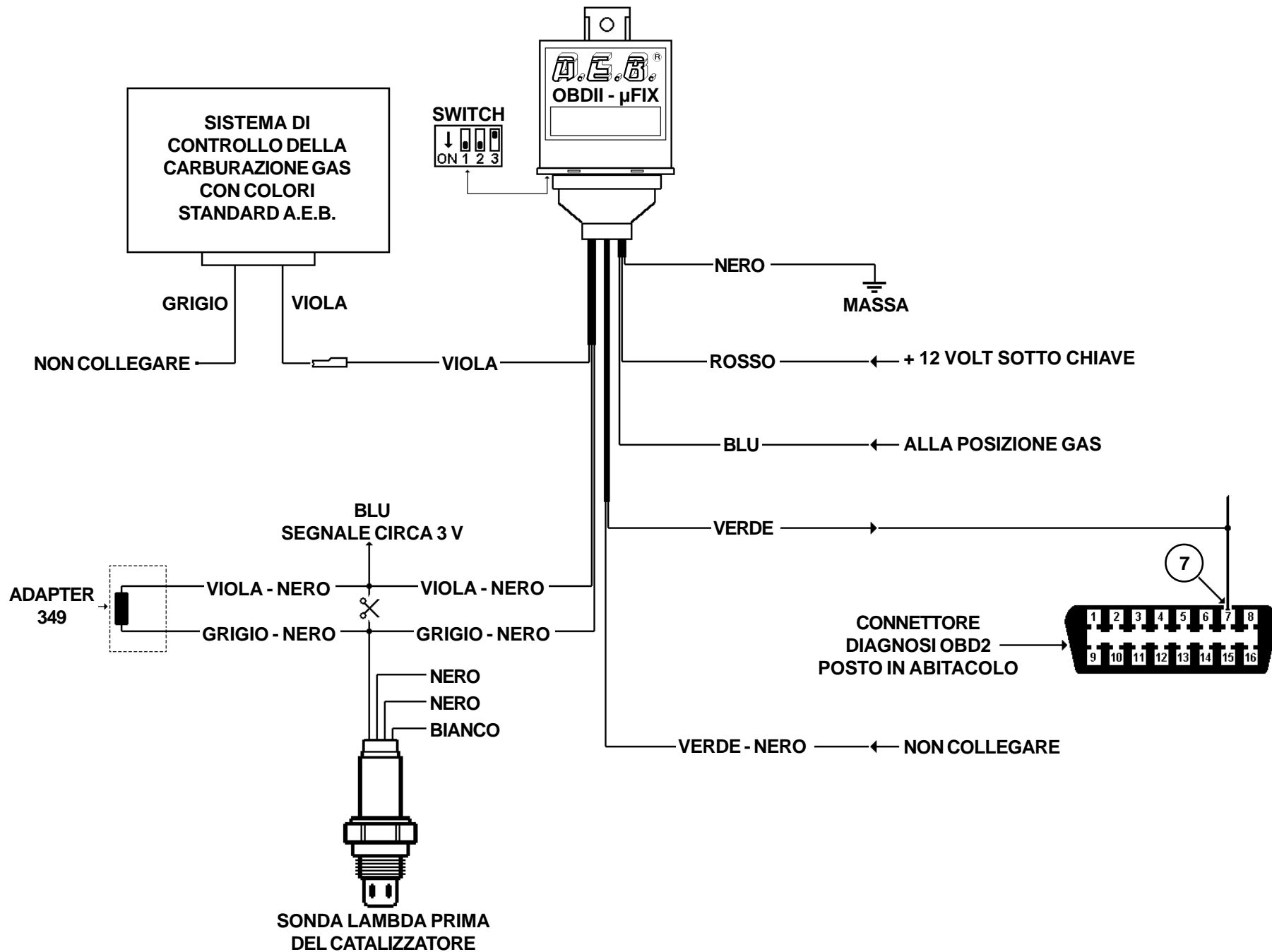

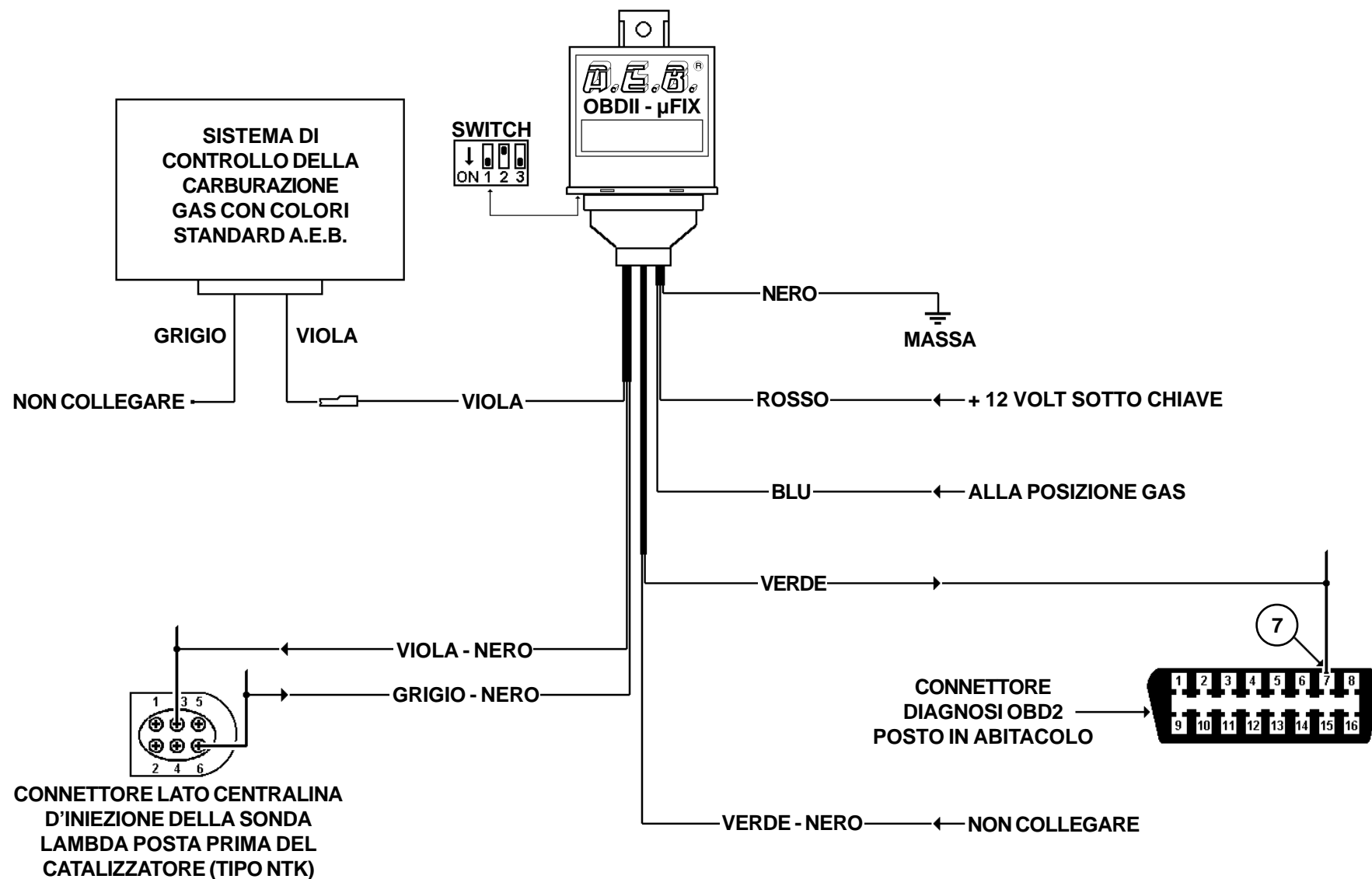

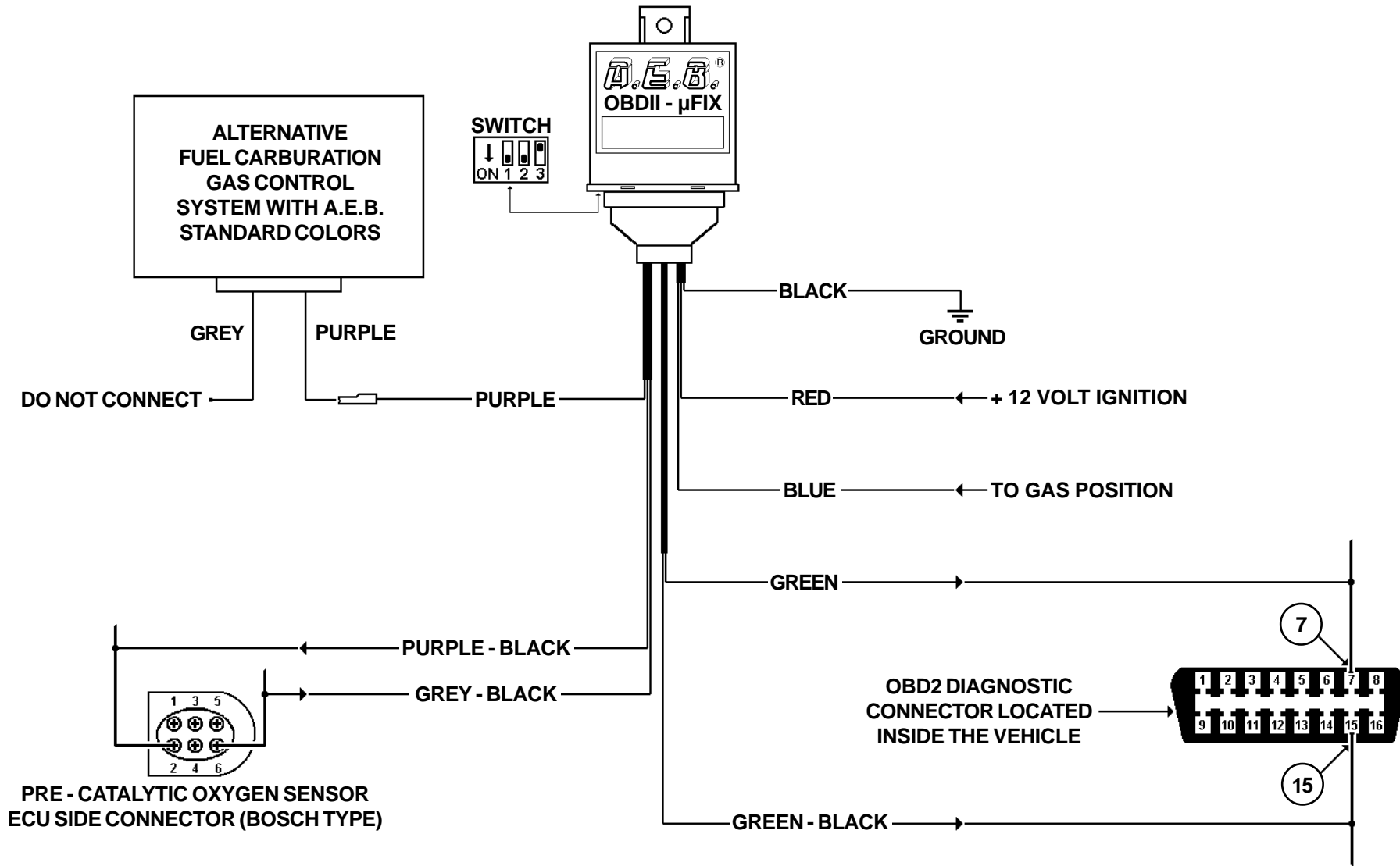

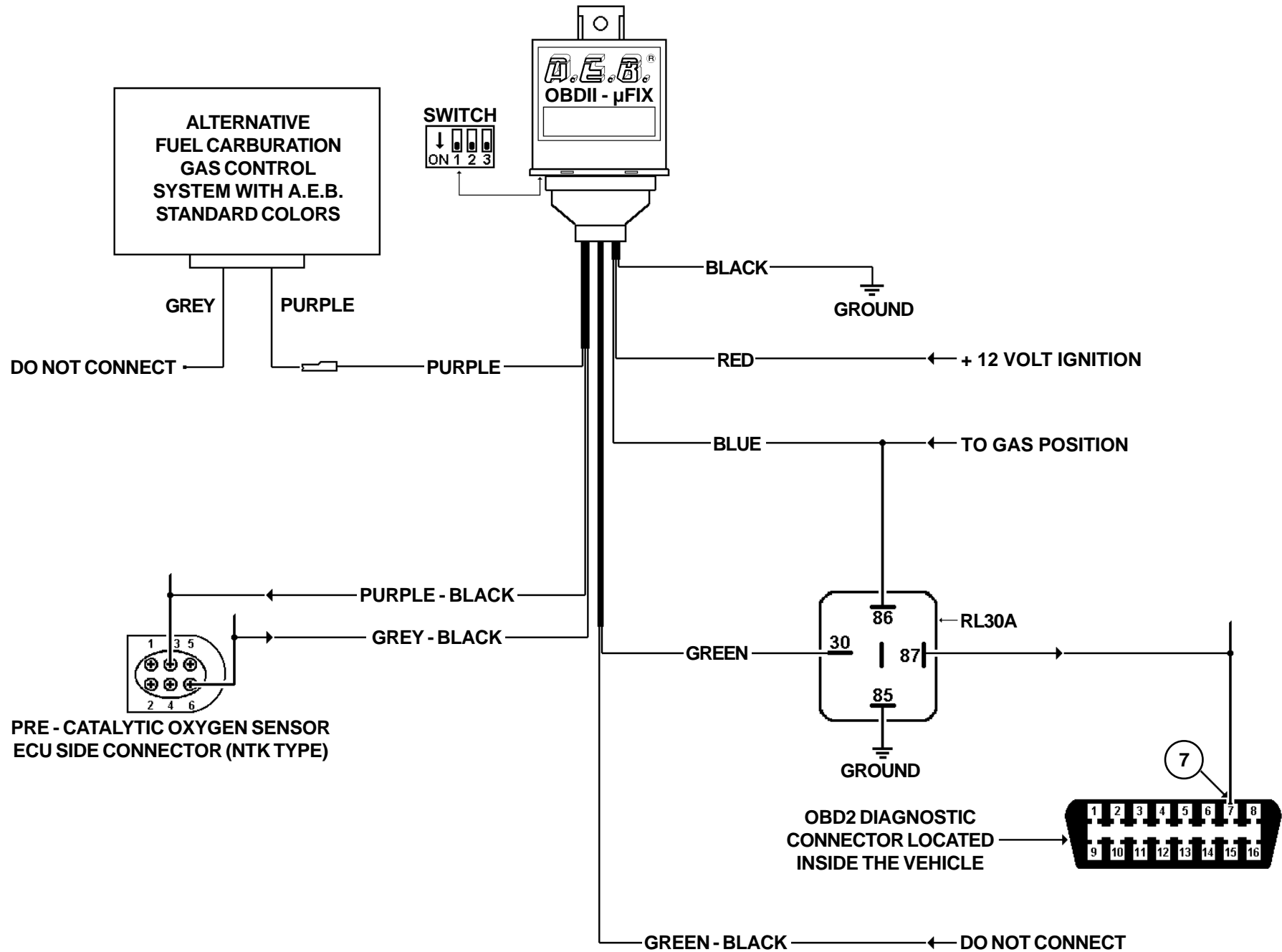

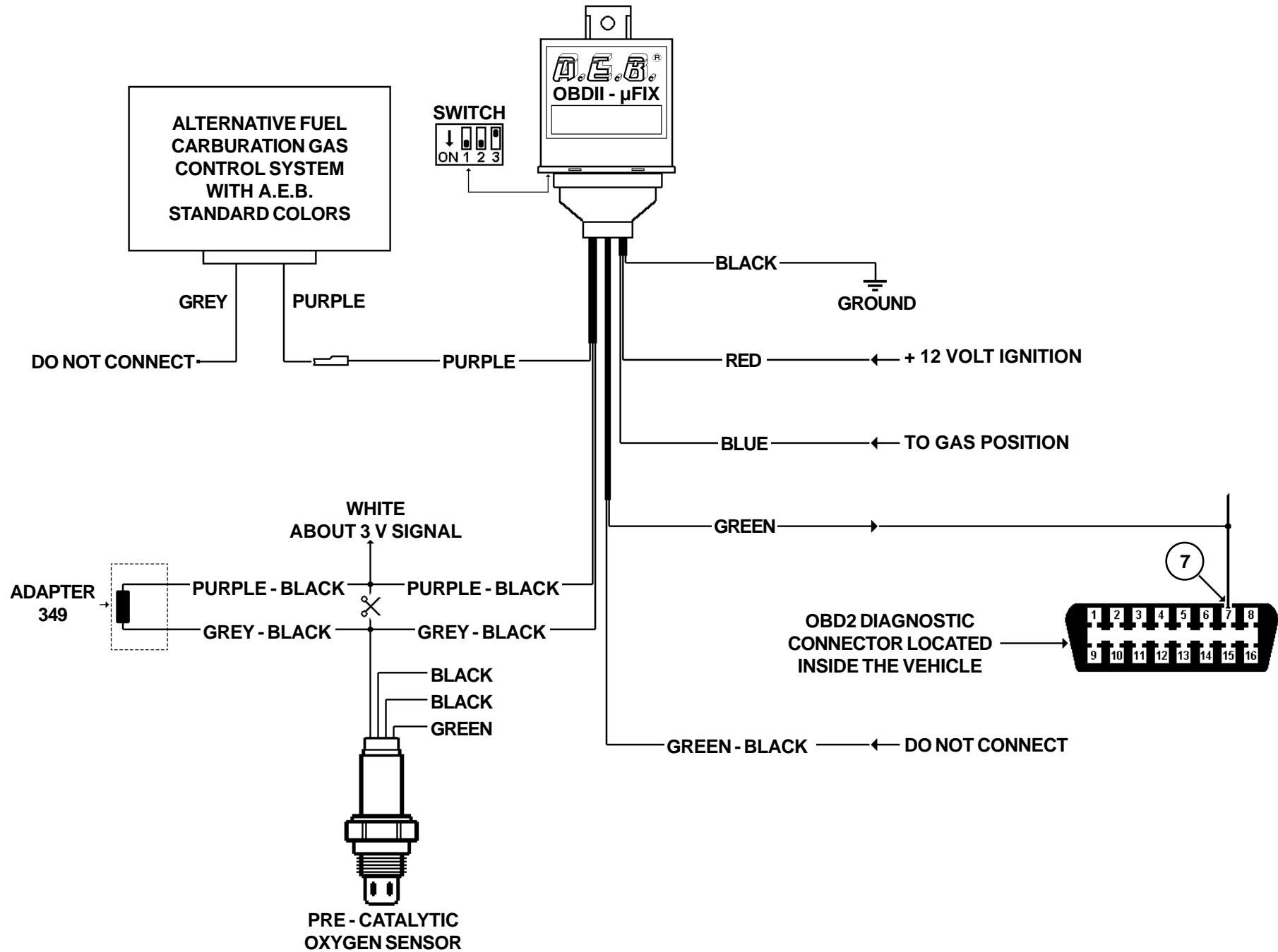

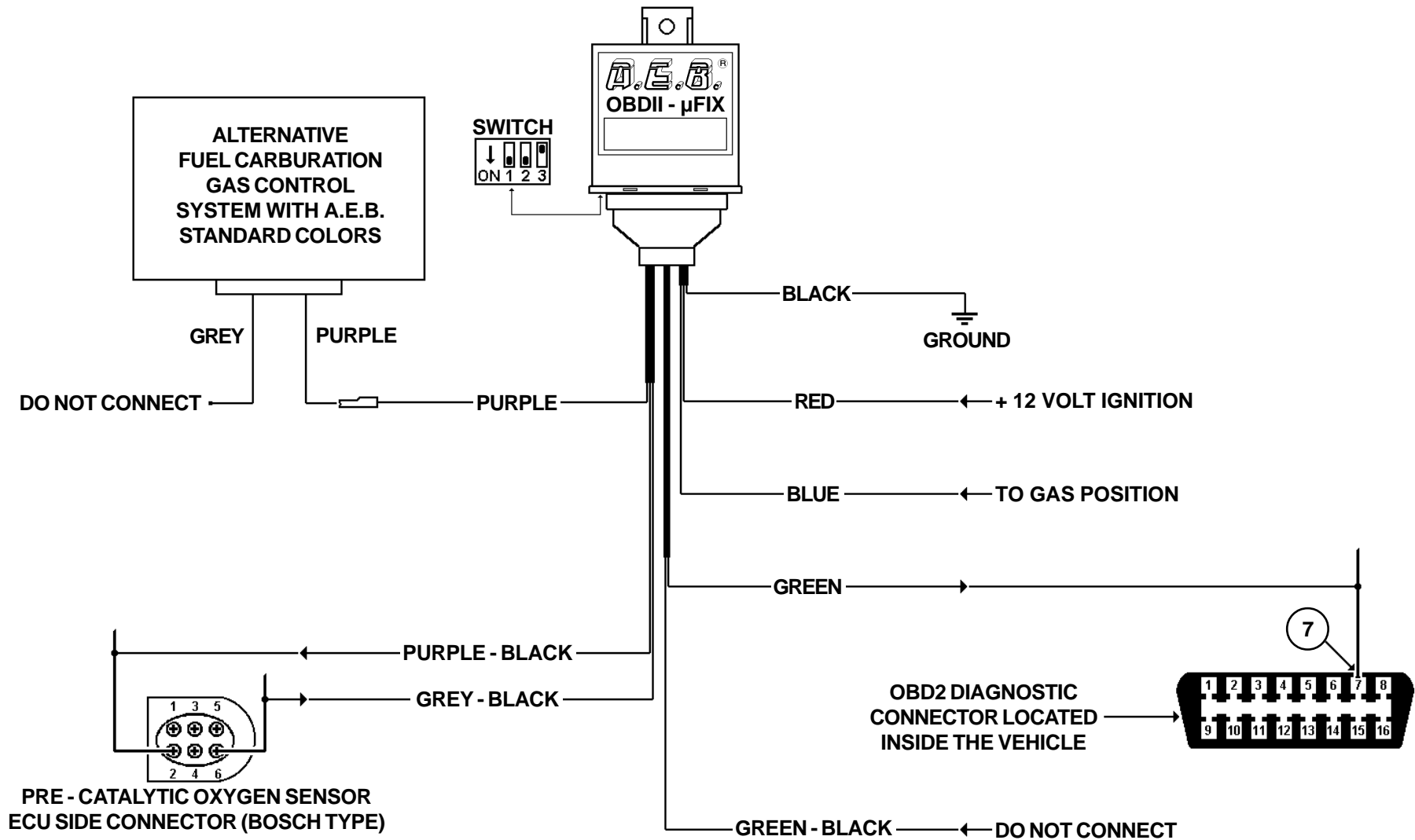

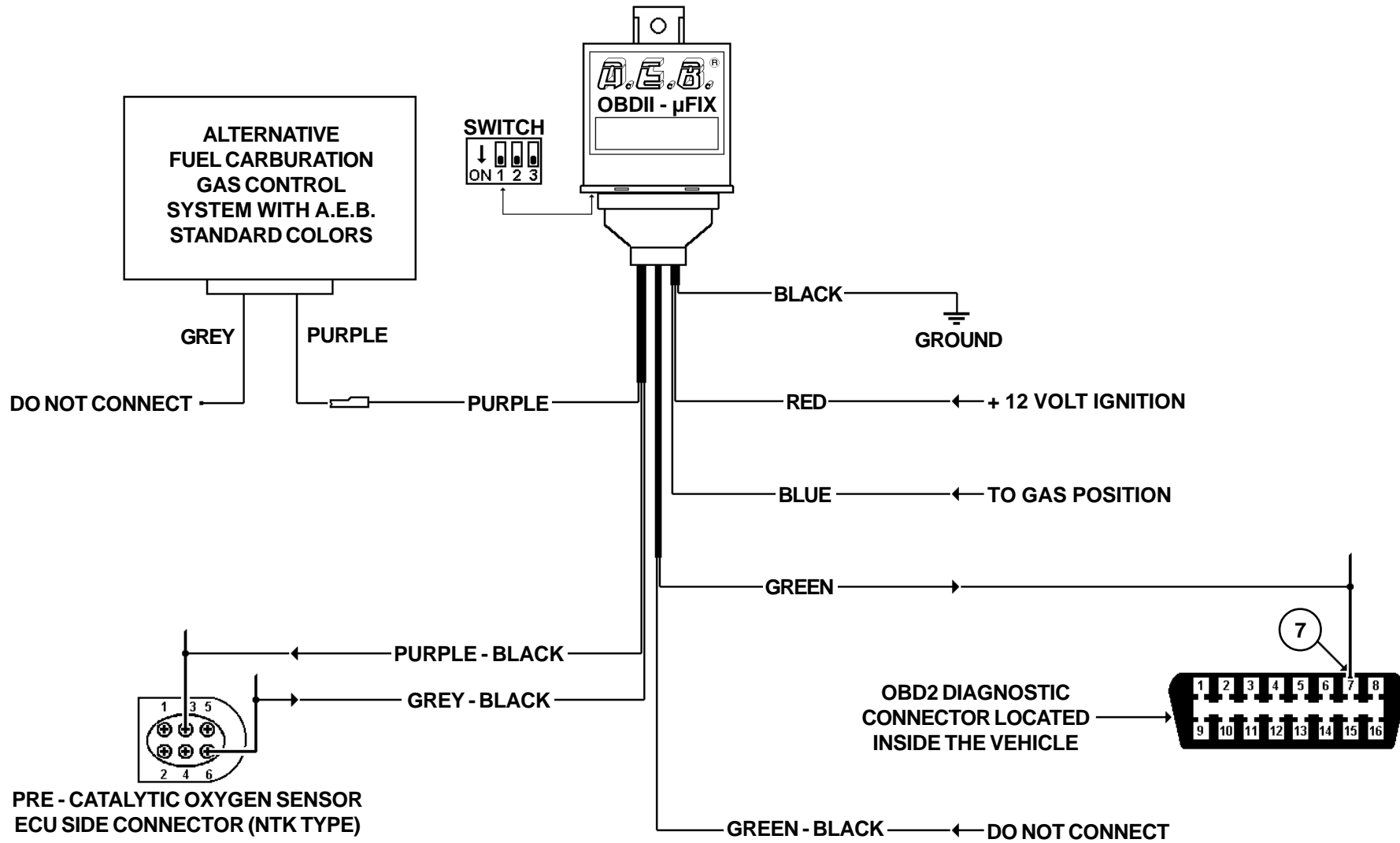

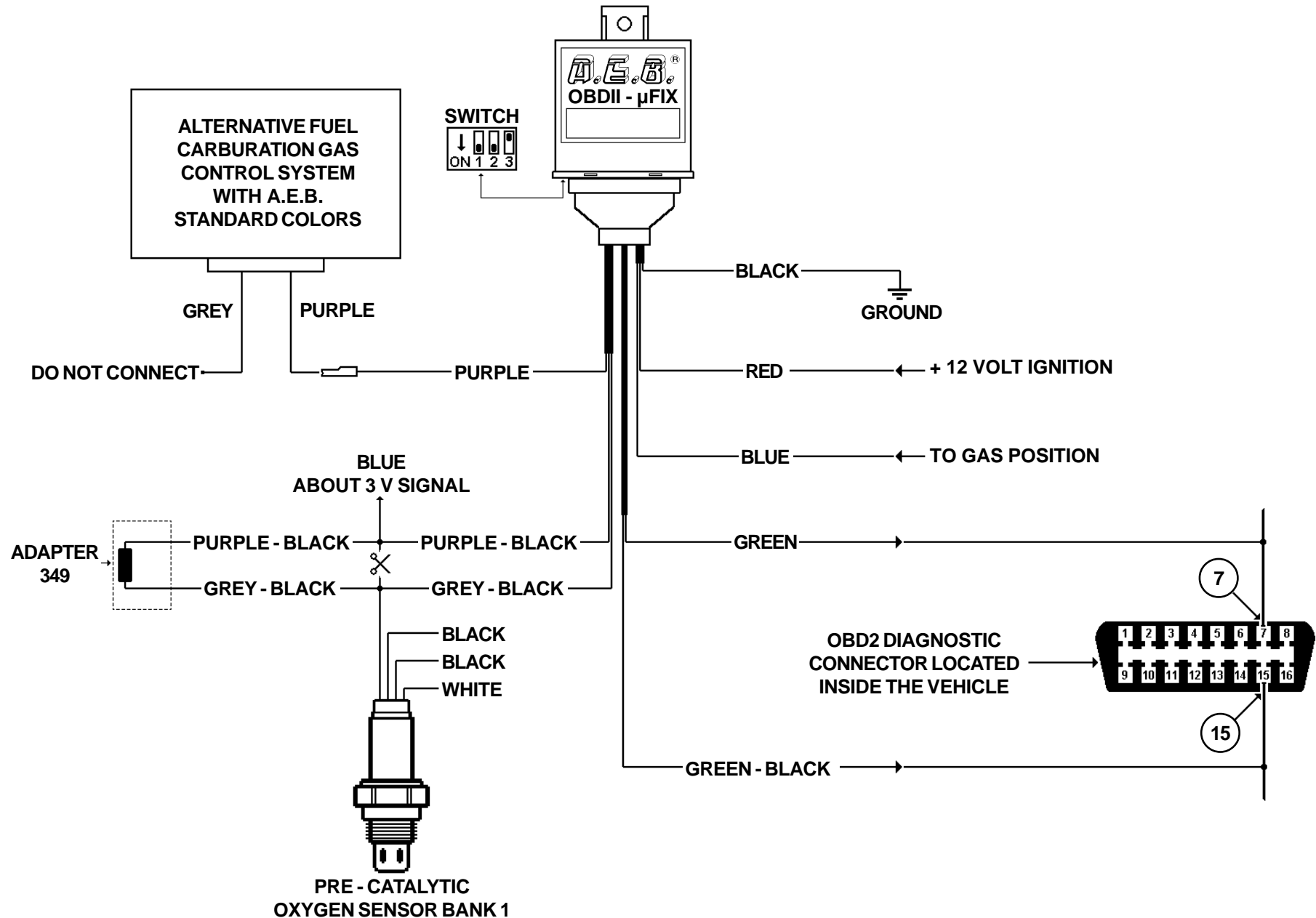

NOTE: THE BANK 1 CORRESPONDE TO CYLINDER 1

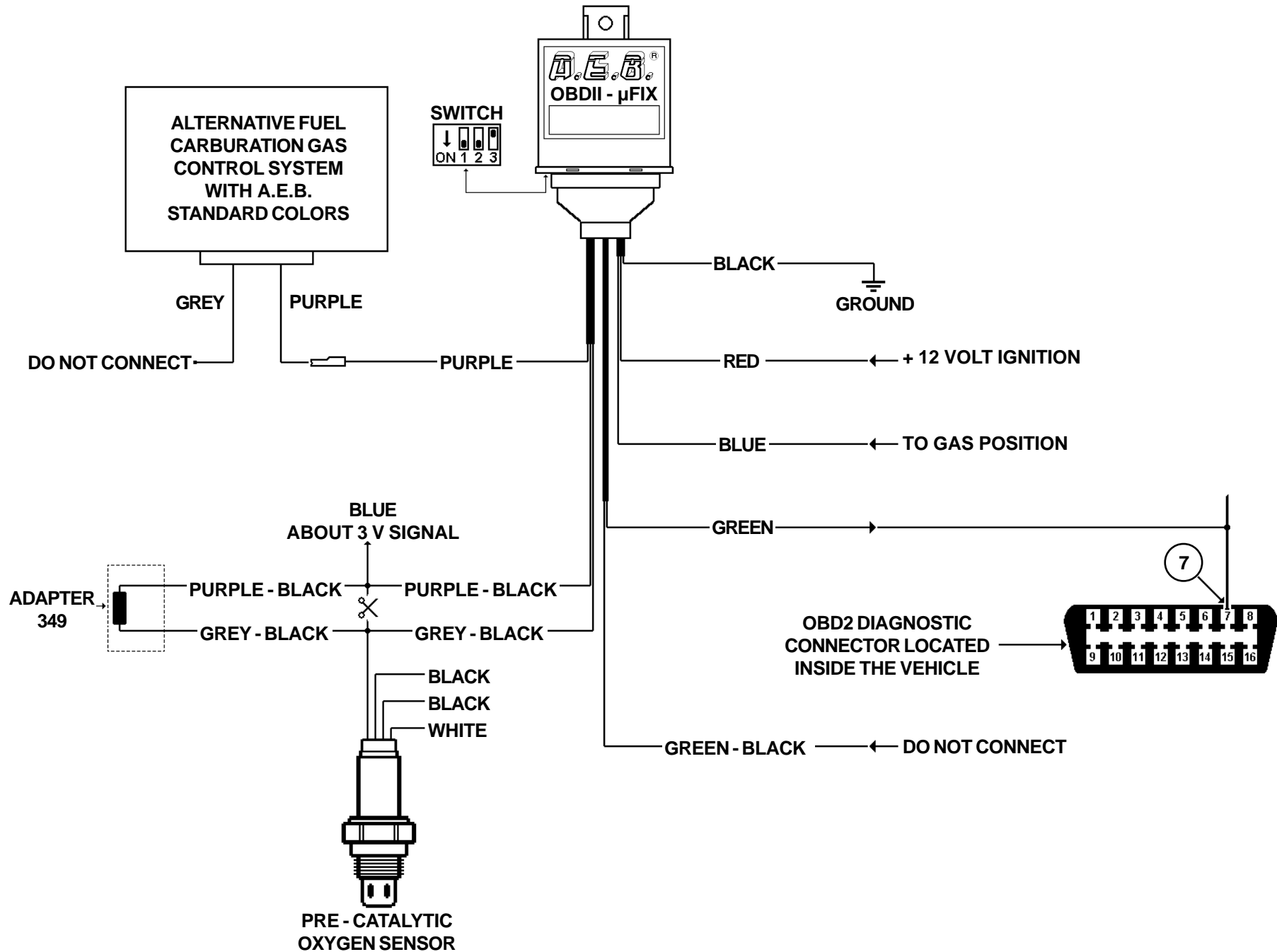

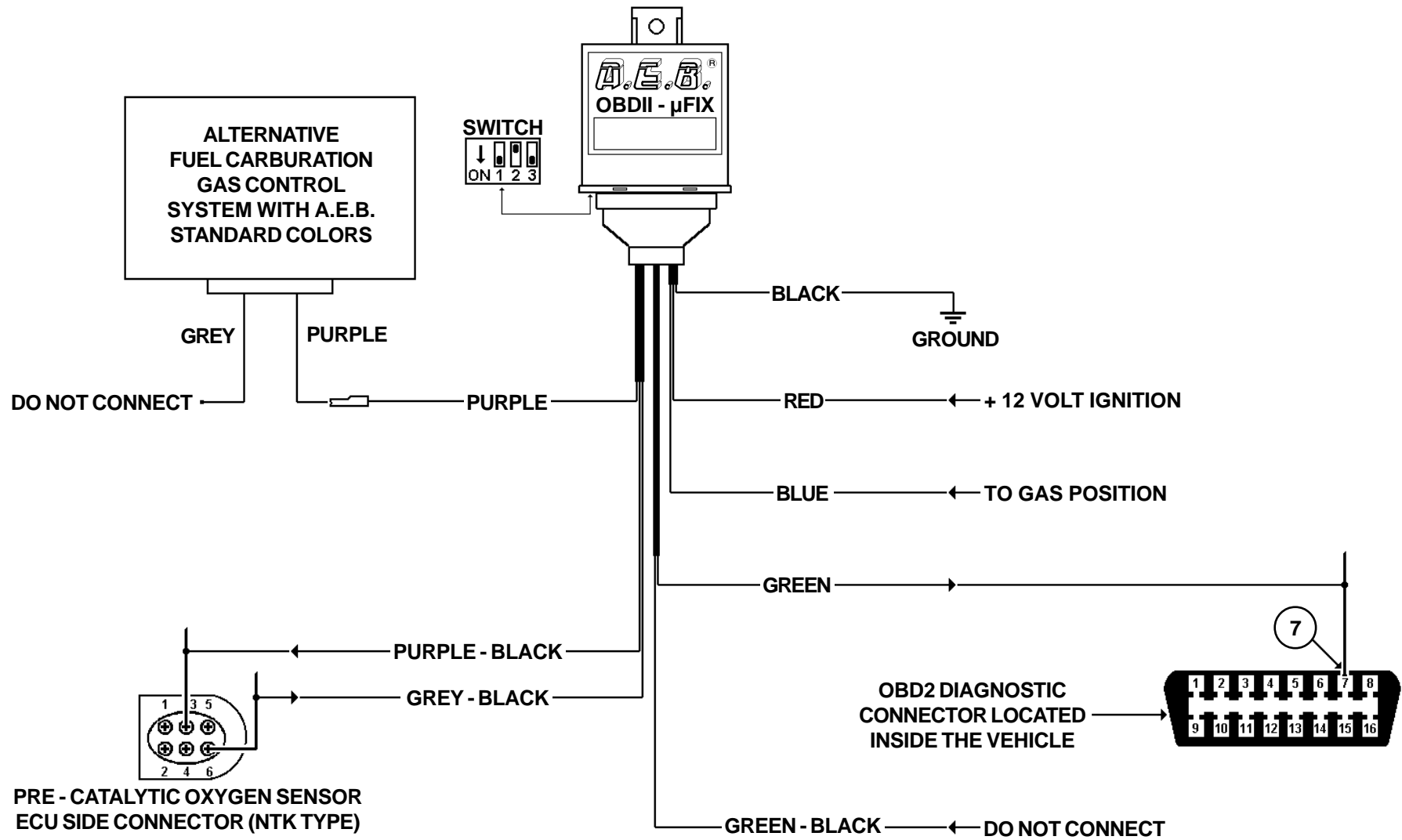

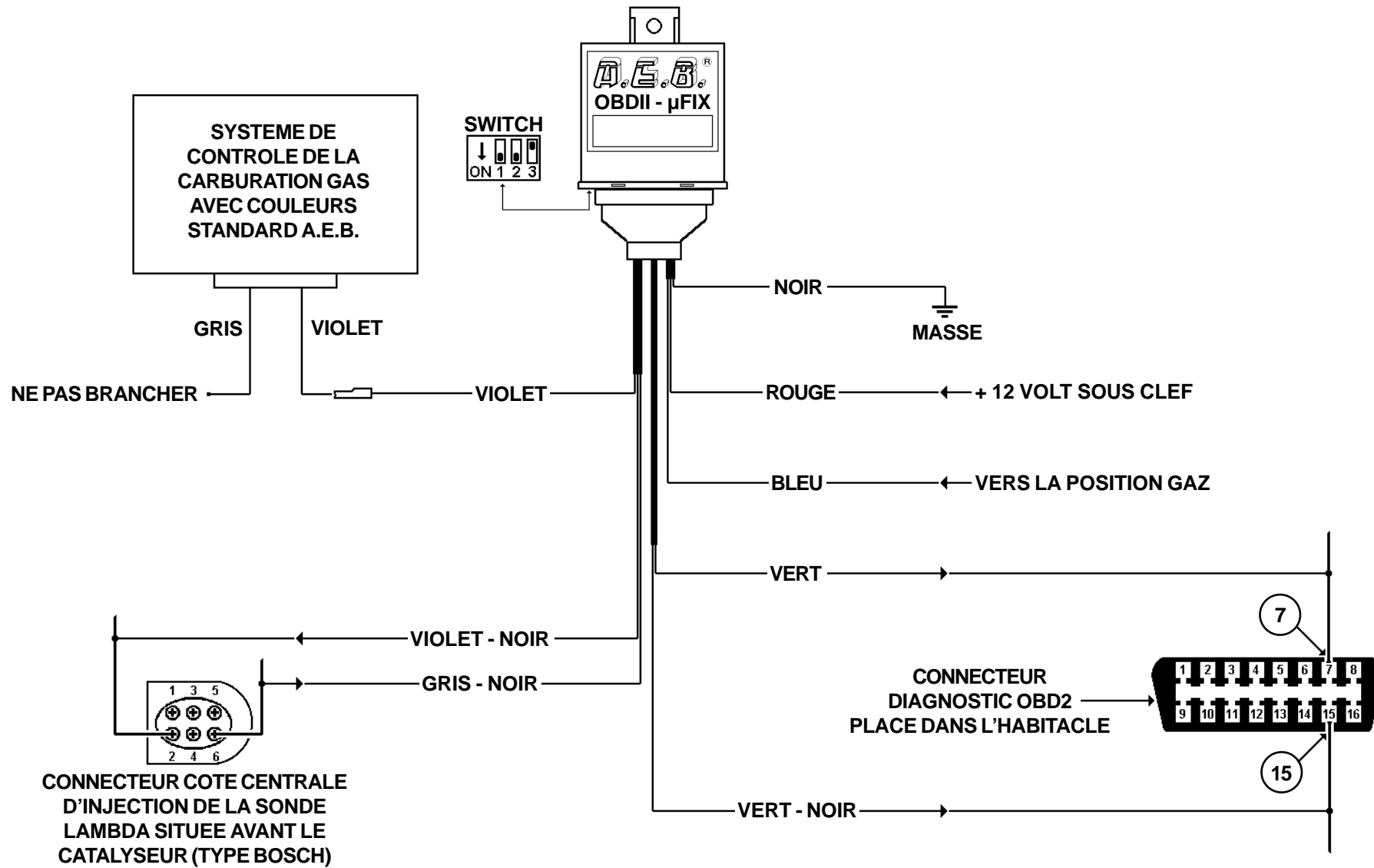

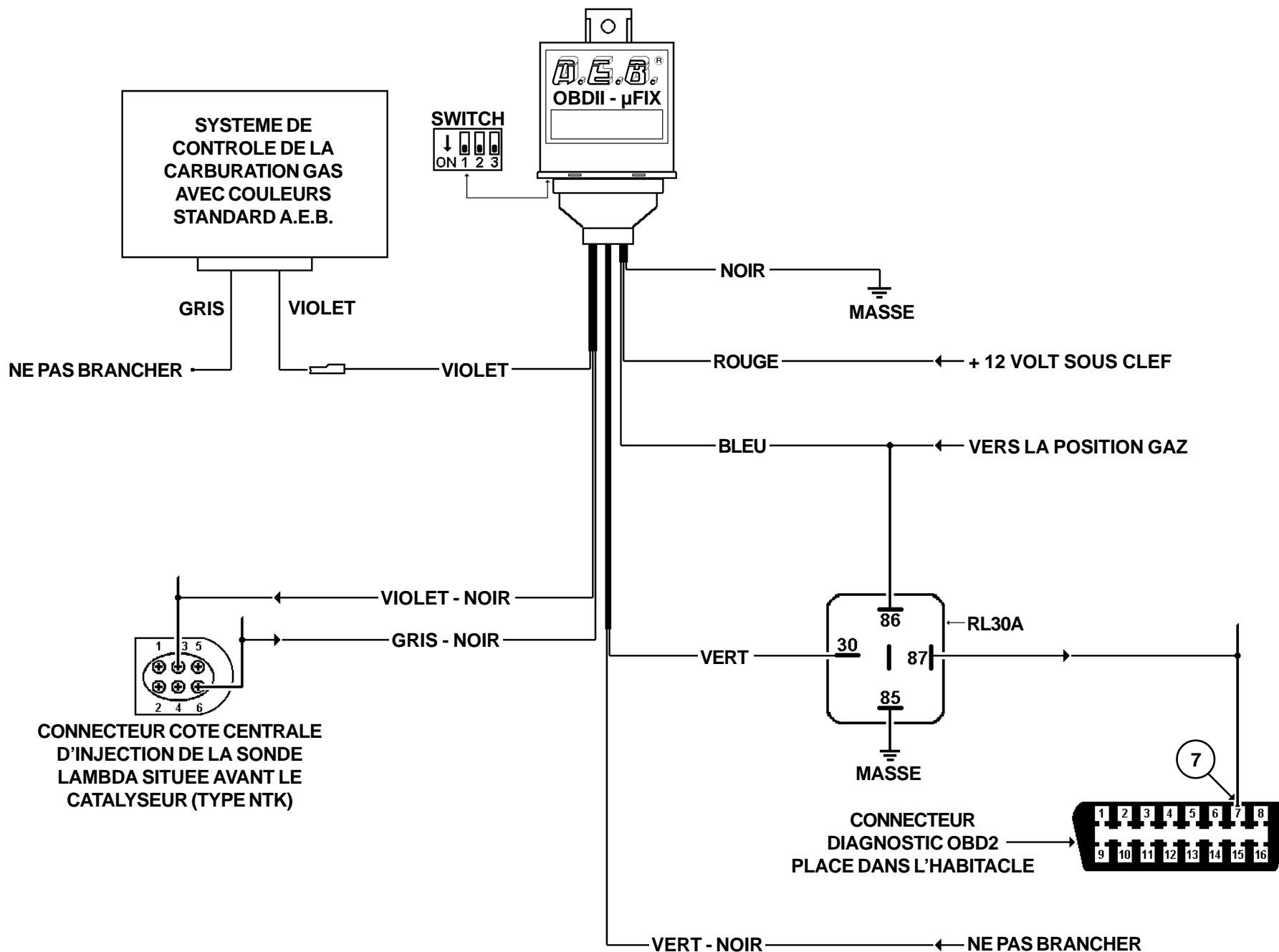

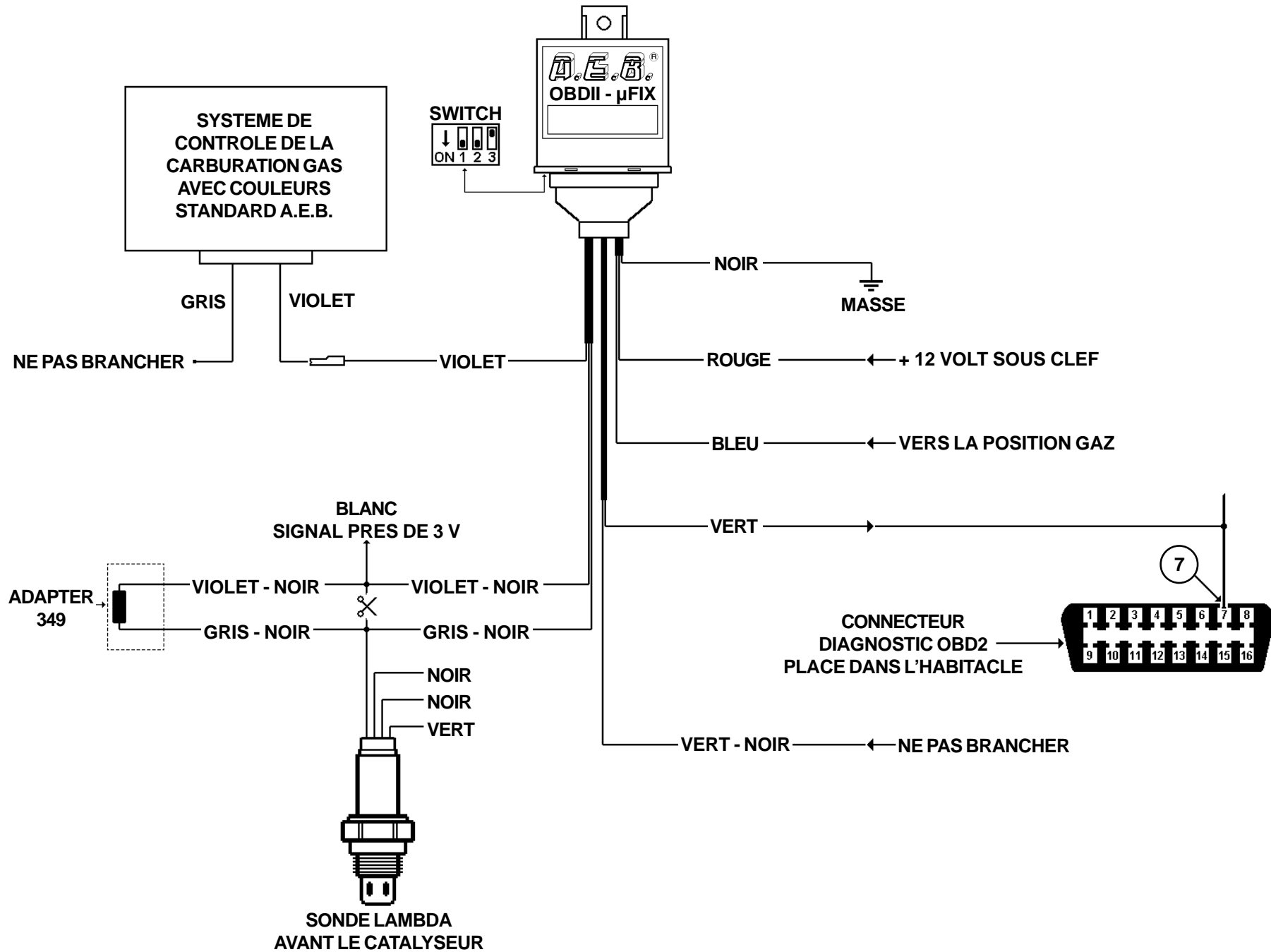

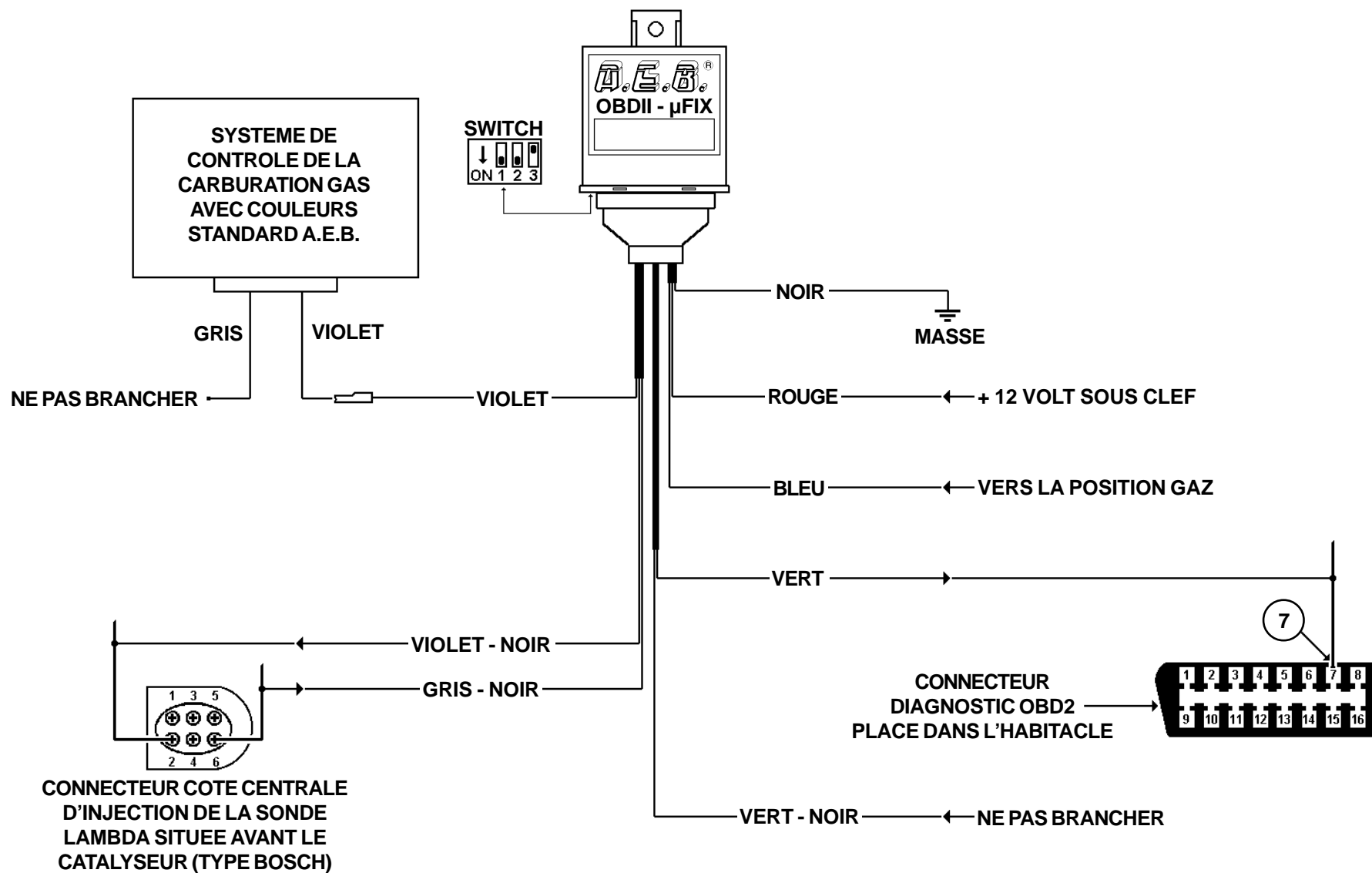

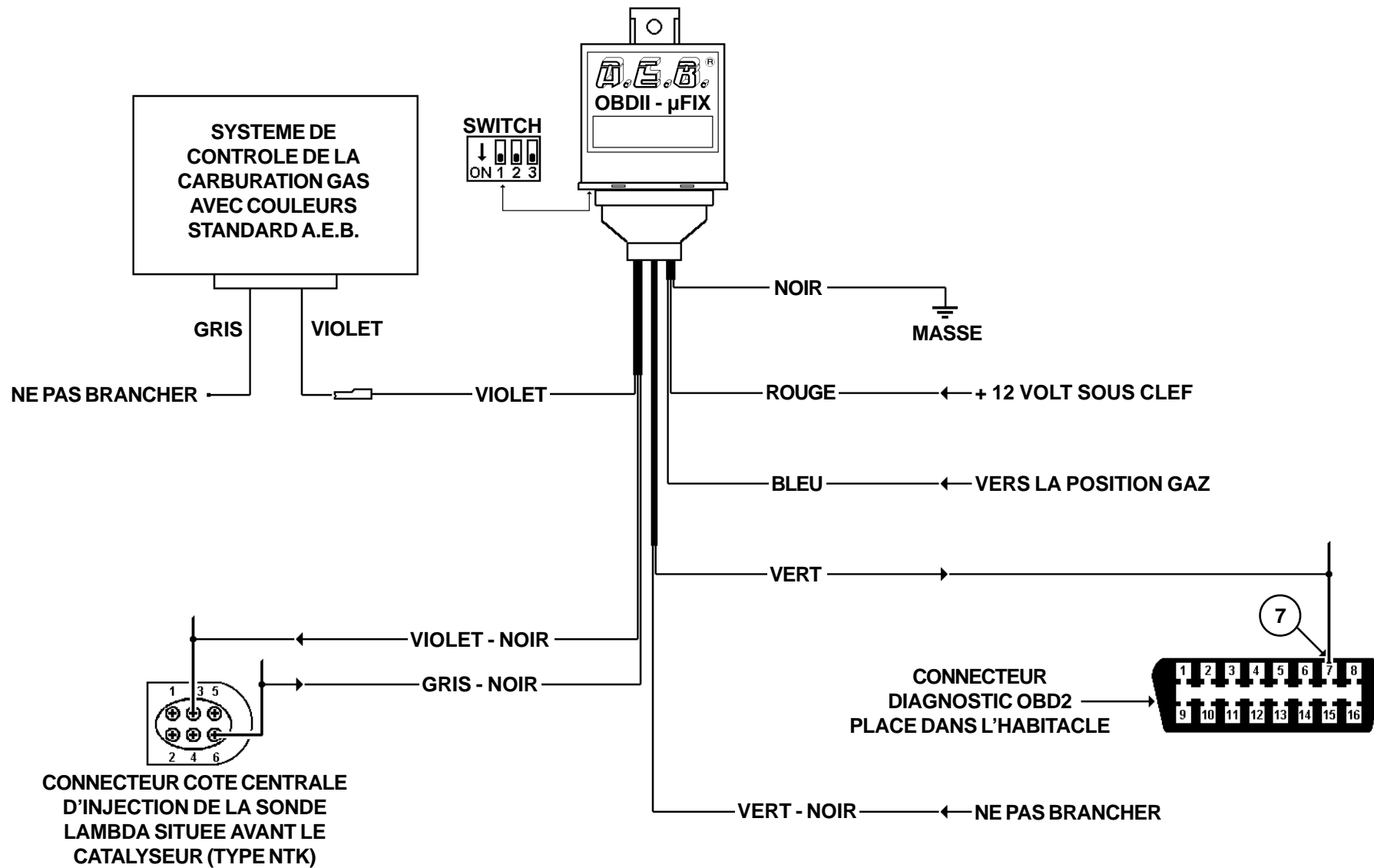

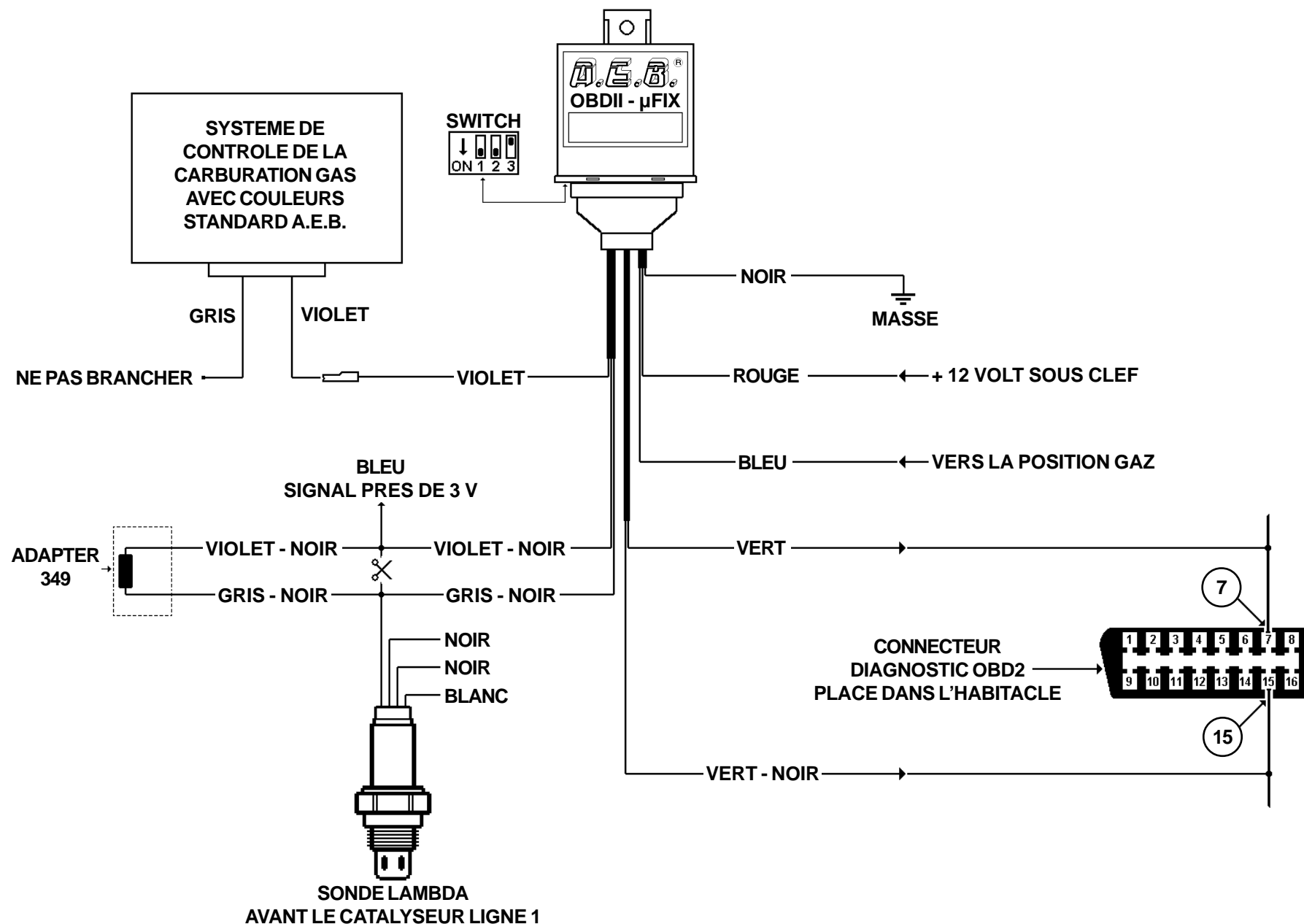

NOTE: LA LIGNE 1 CORRESPOND AU CYLINDRE 1

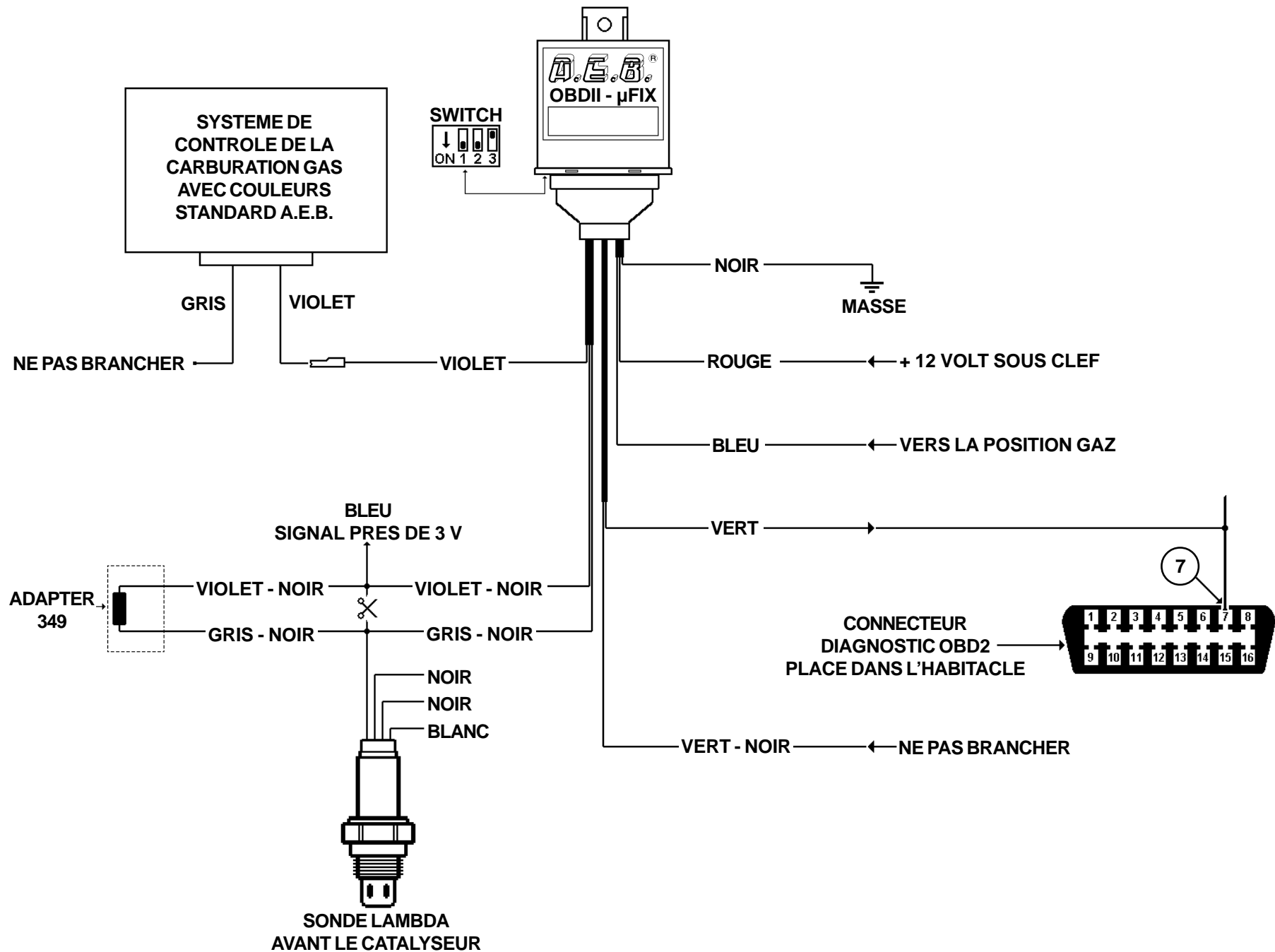

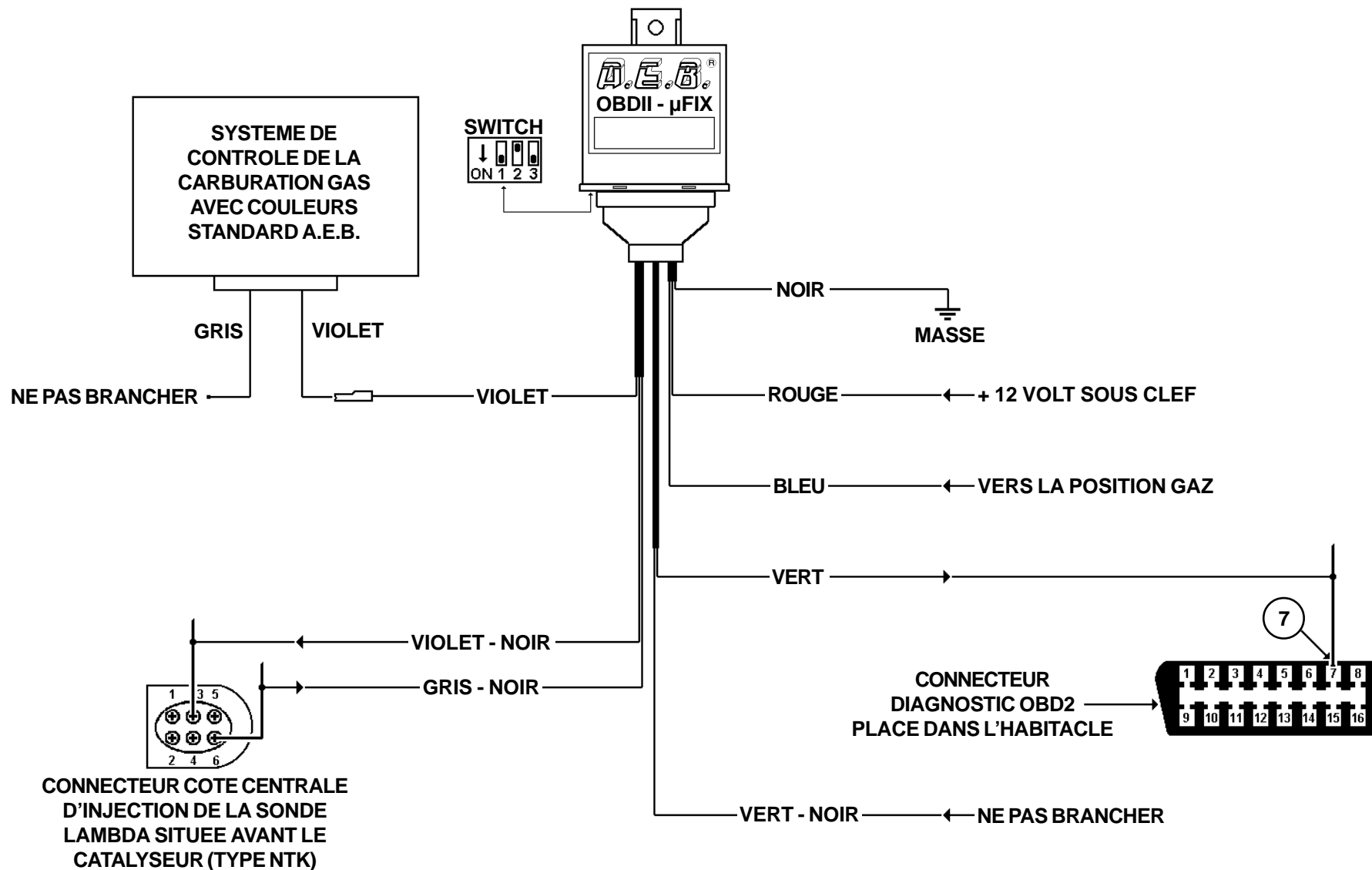

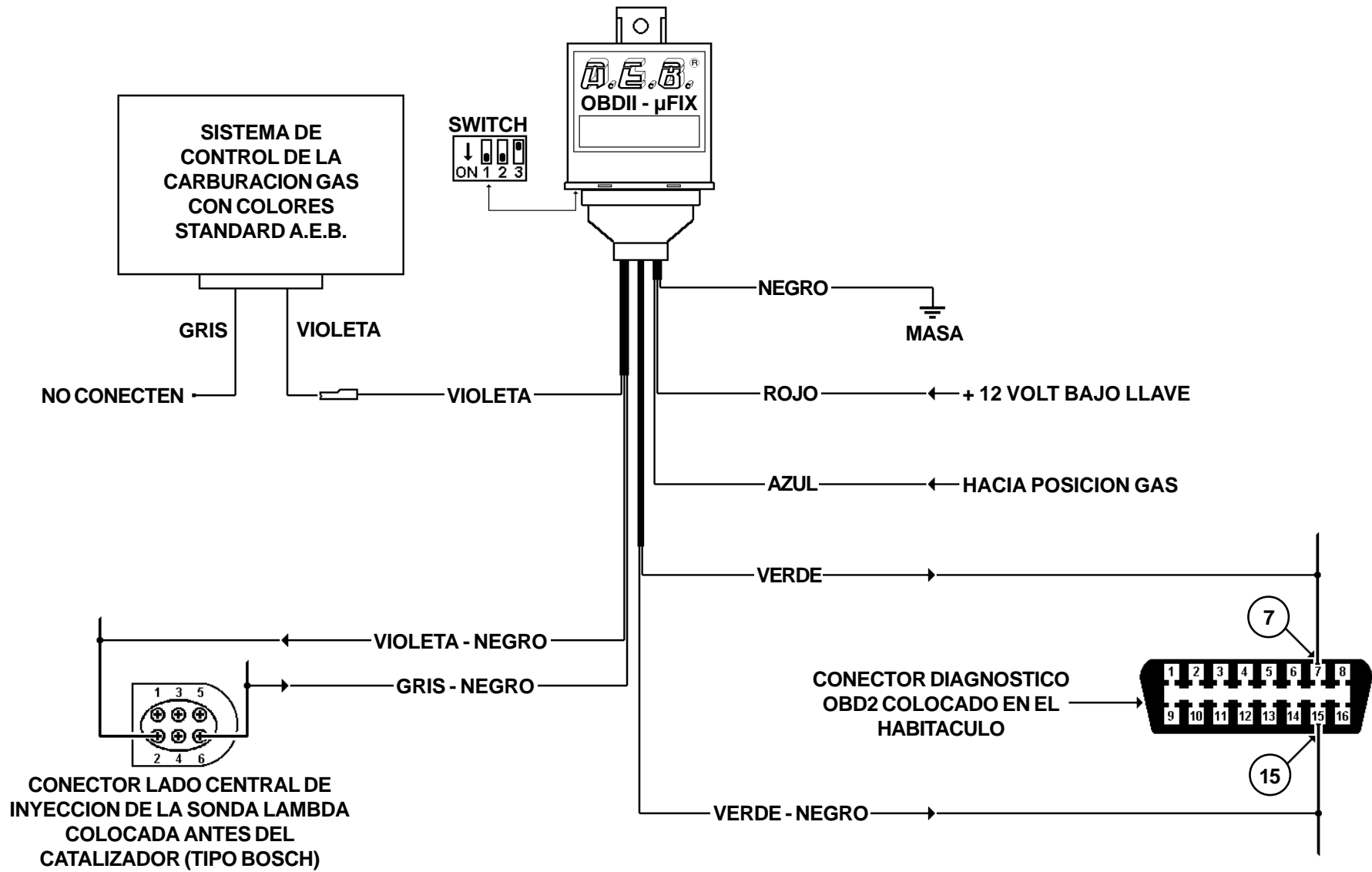

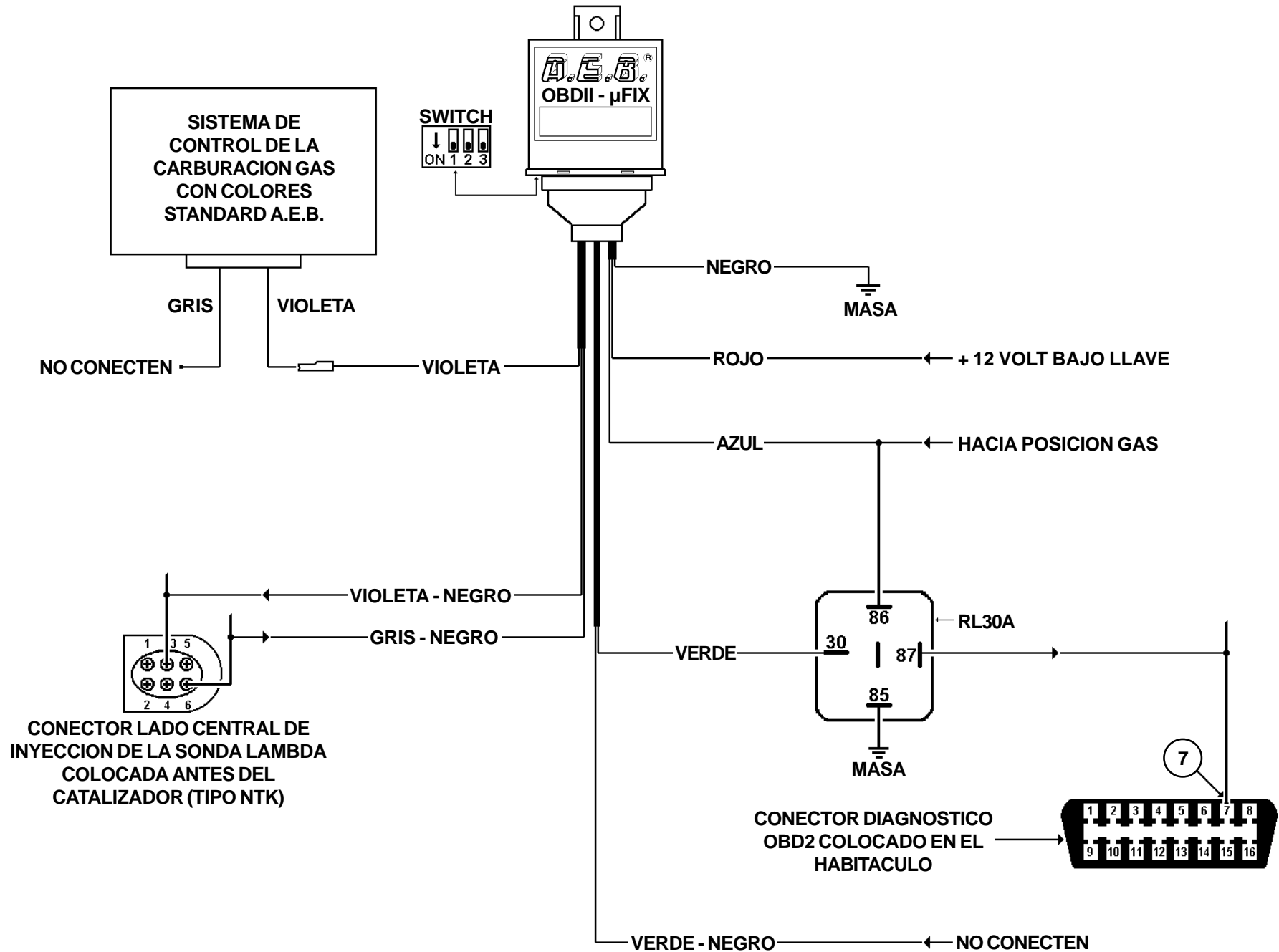

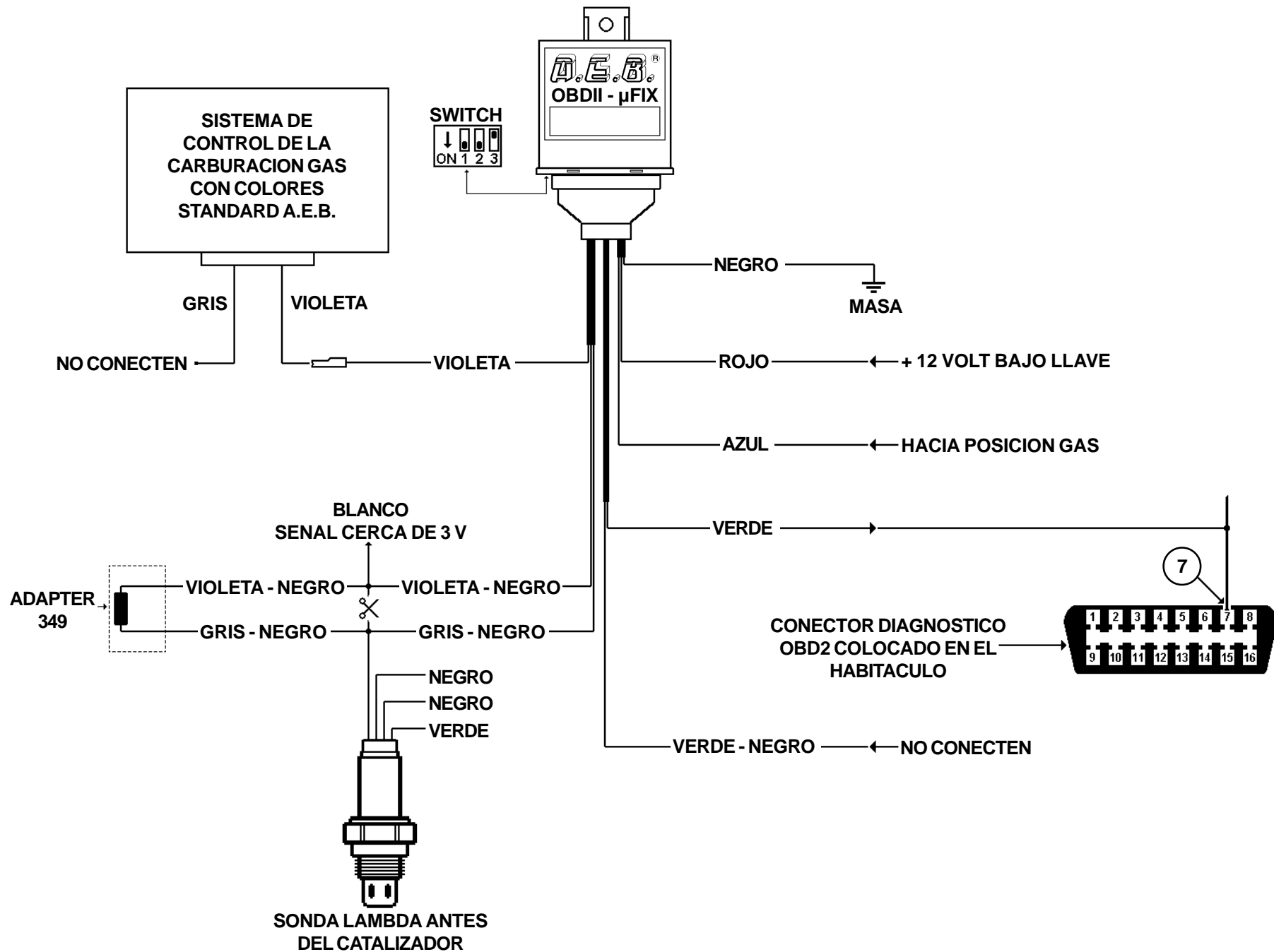

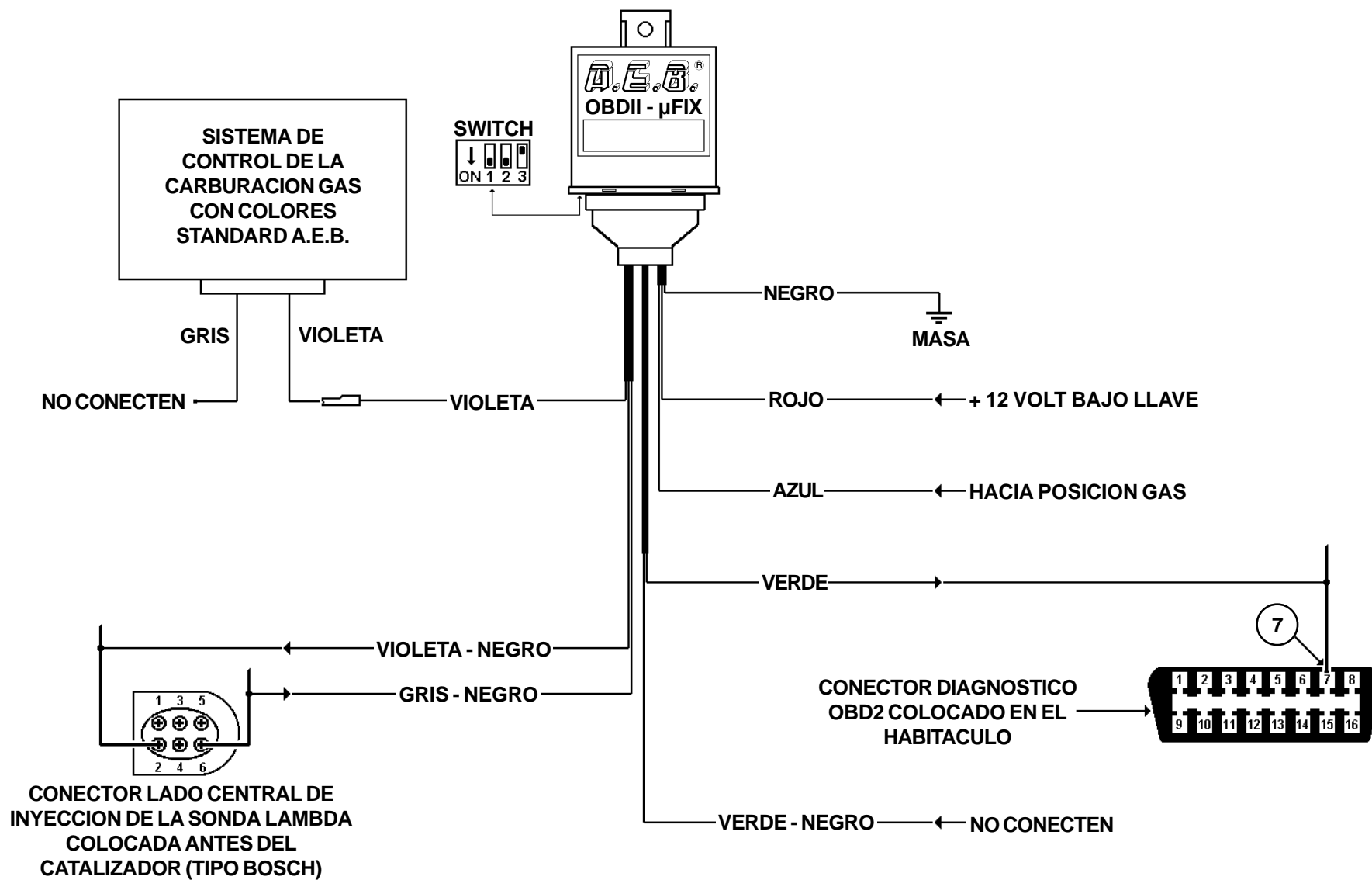

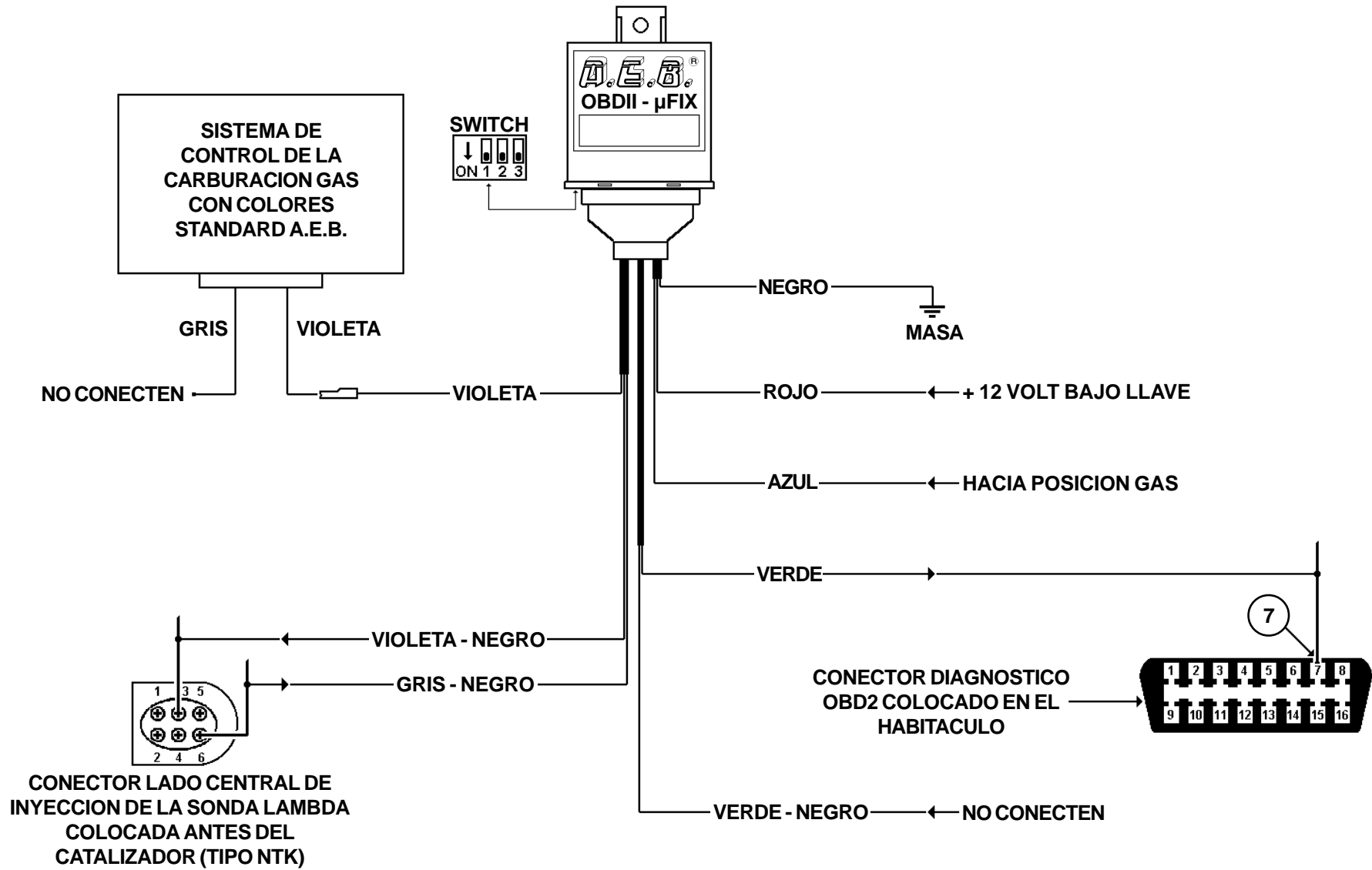

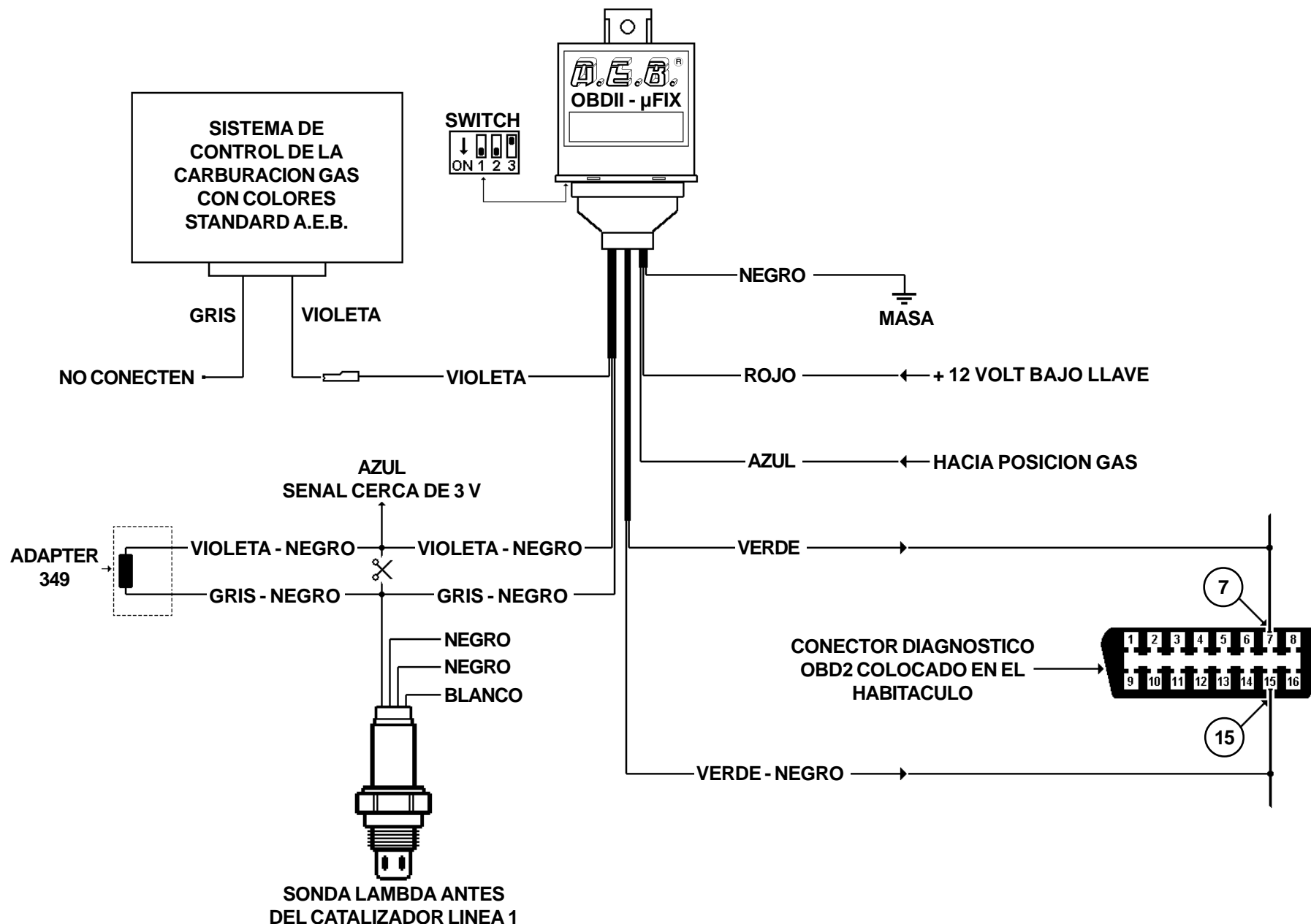

NOTA: LA LINEA 1 SE ENCUENTRA EN CORRESPONDENCIA DEL CILINDRO 1

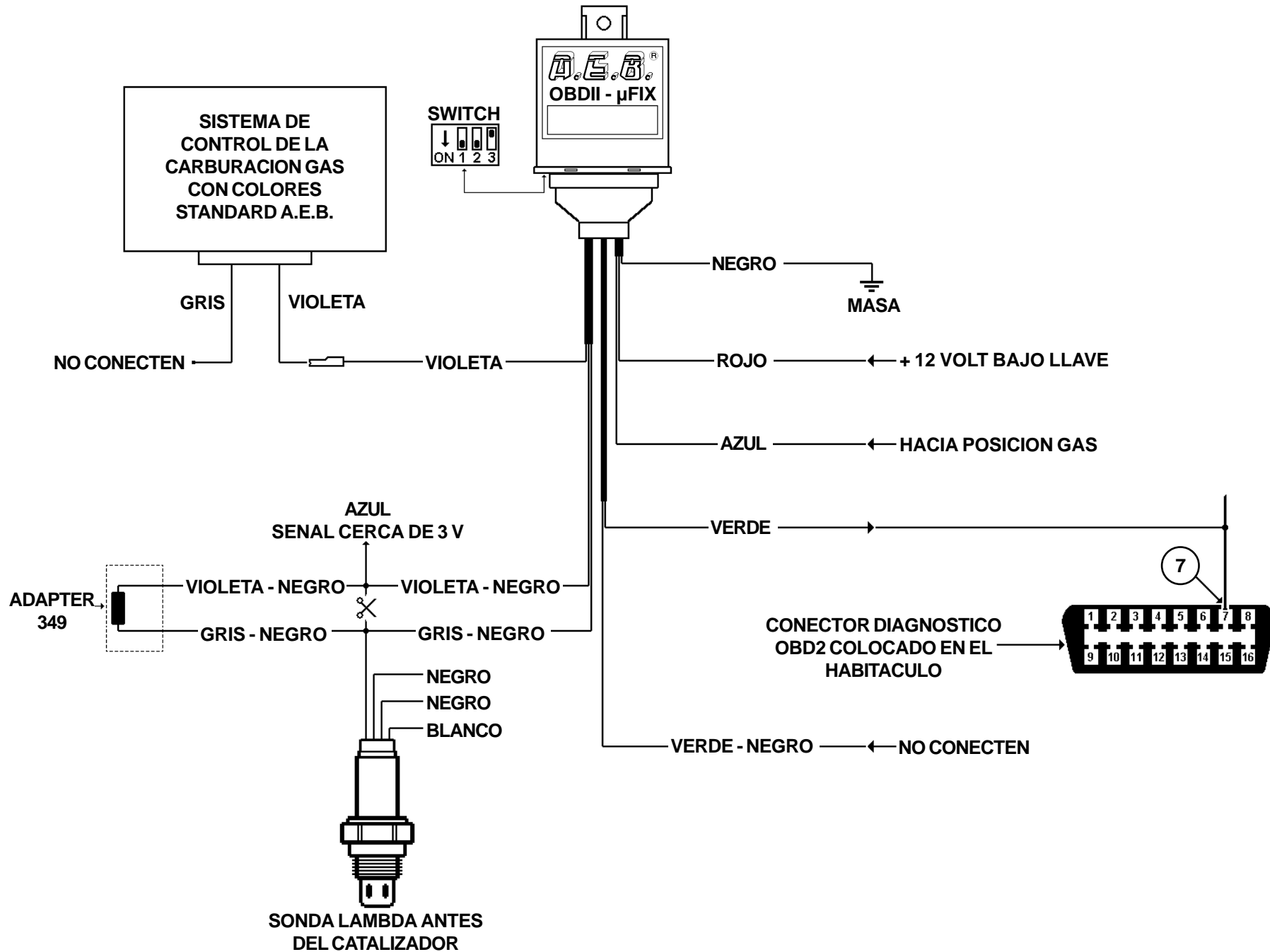

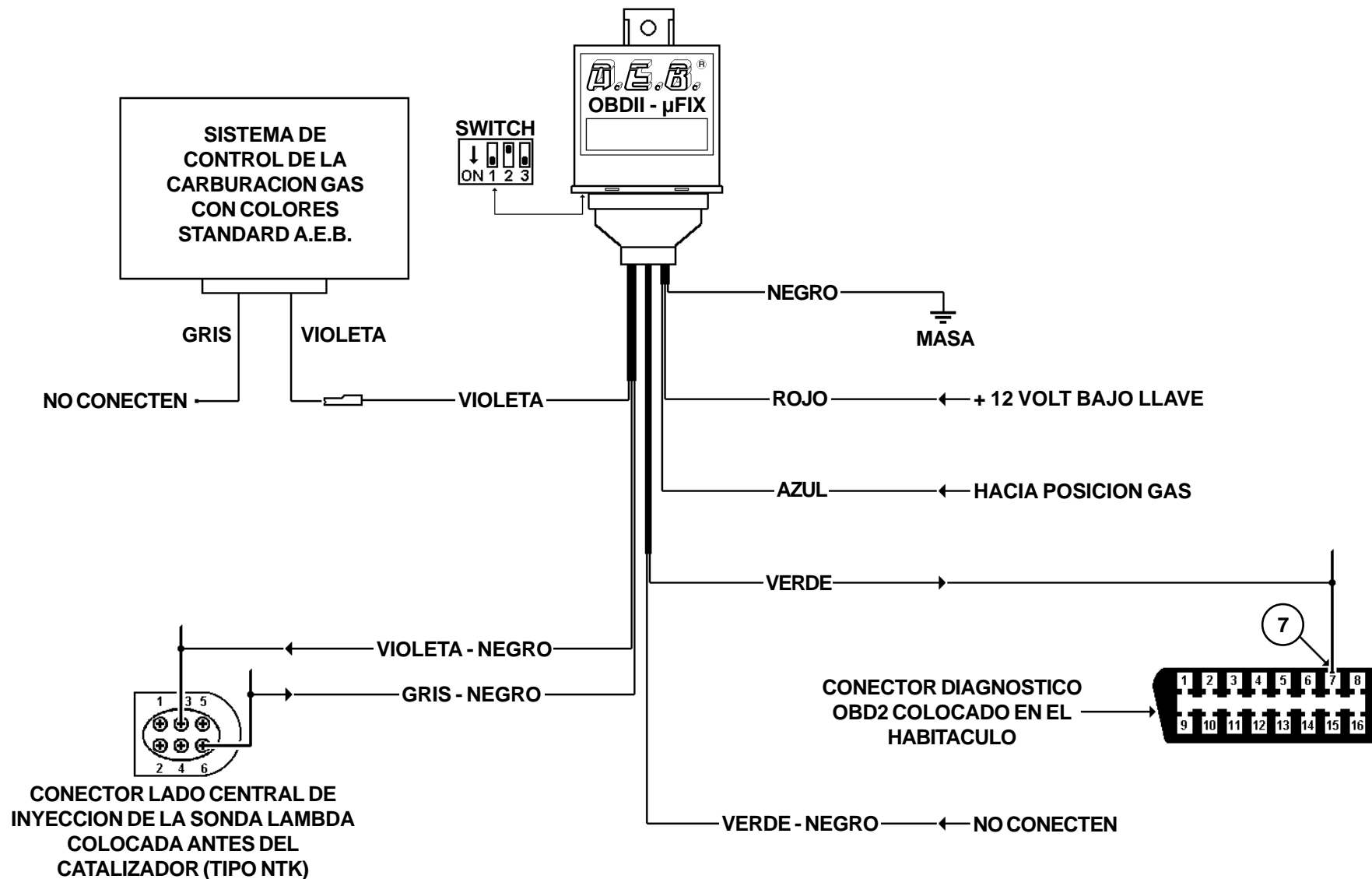

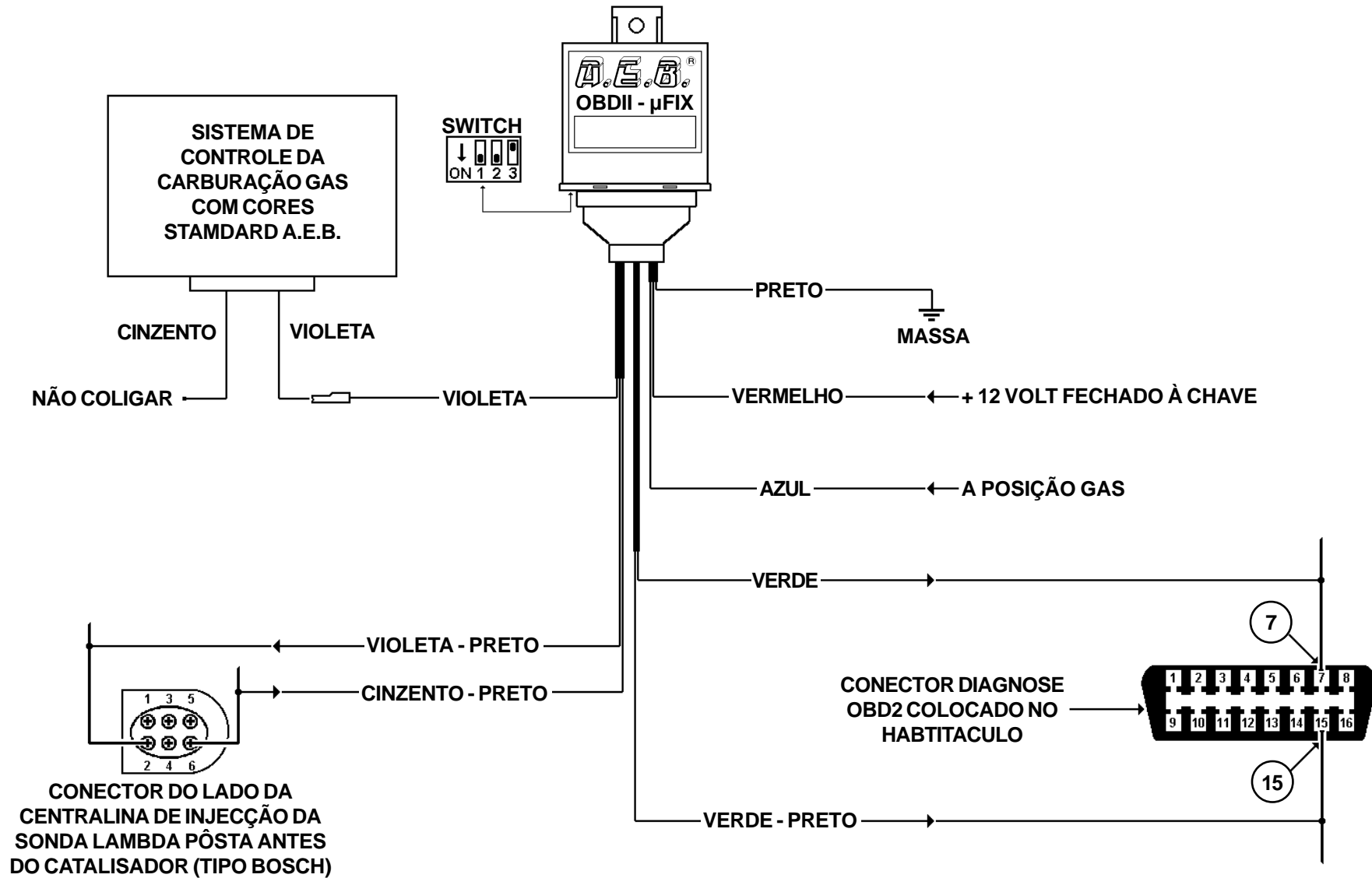

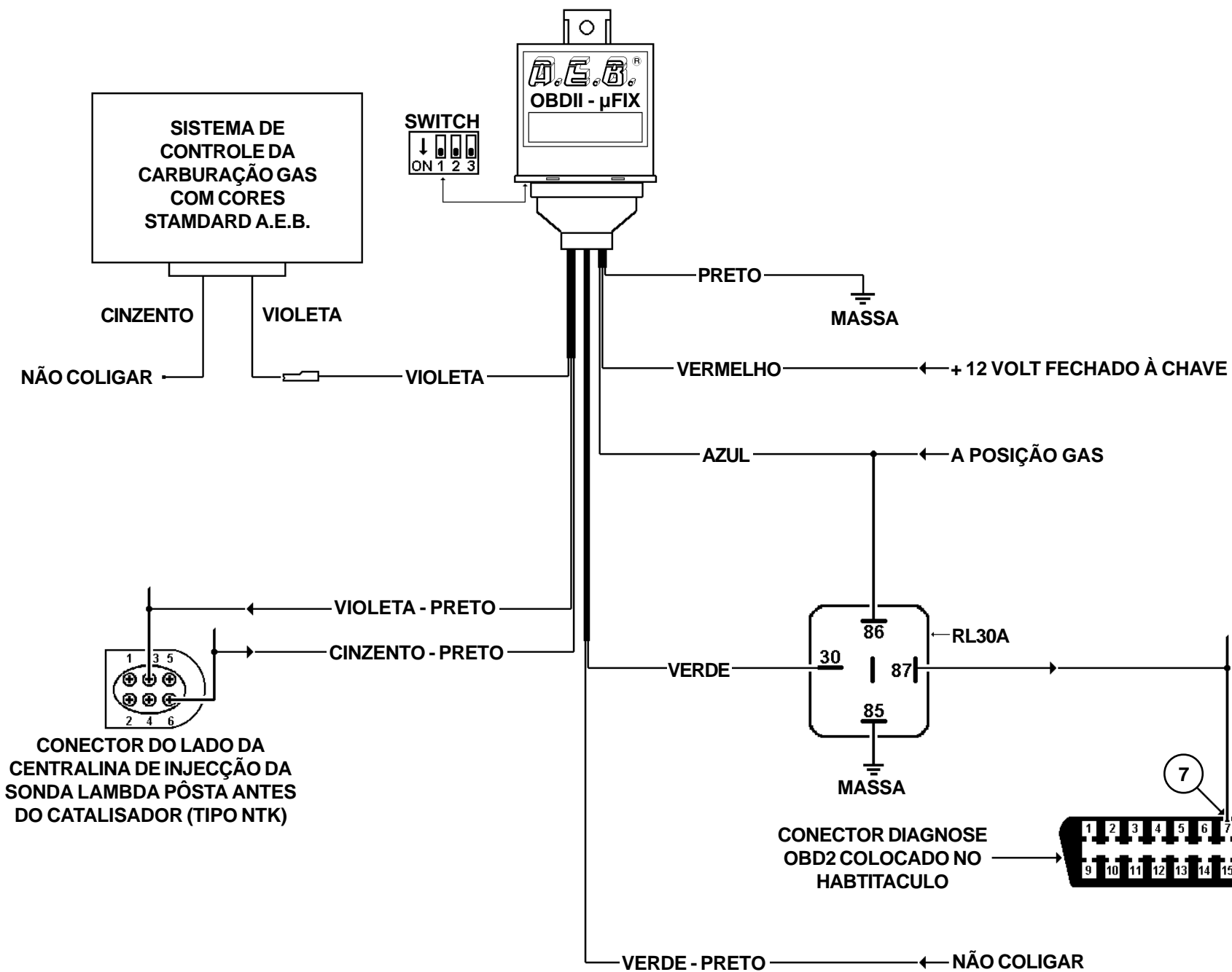

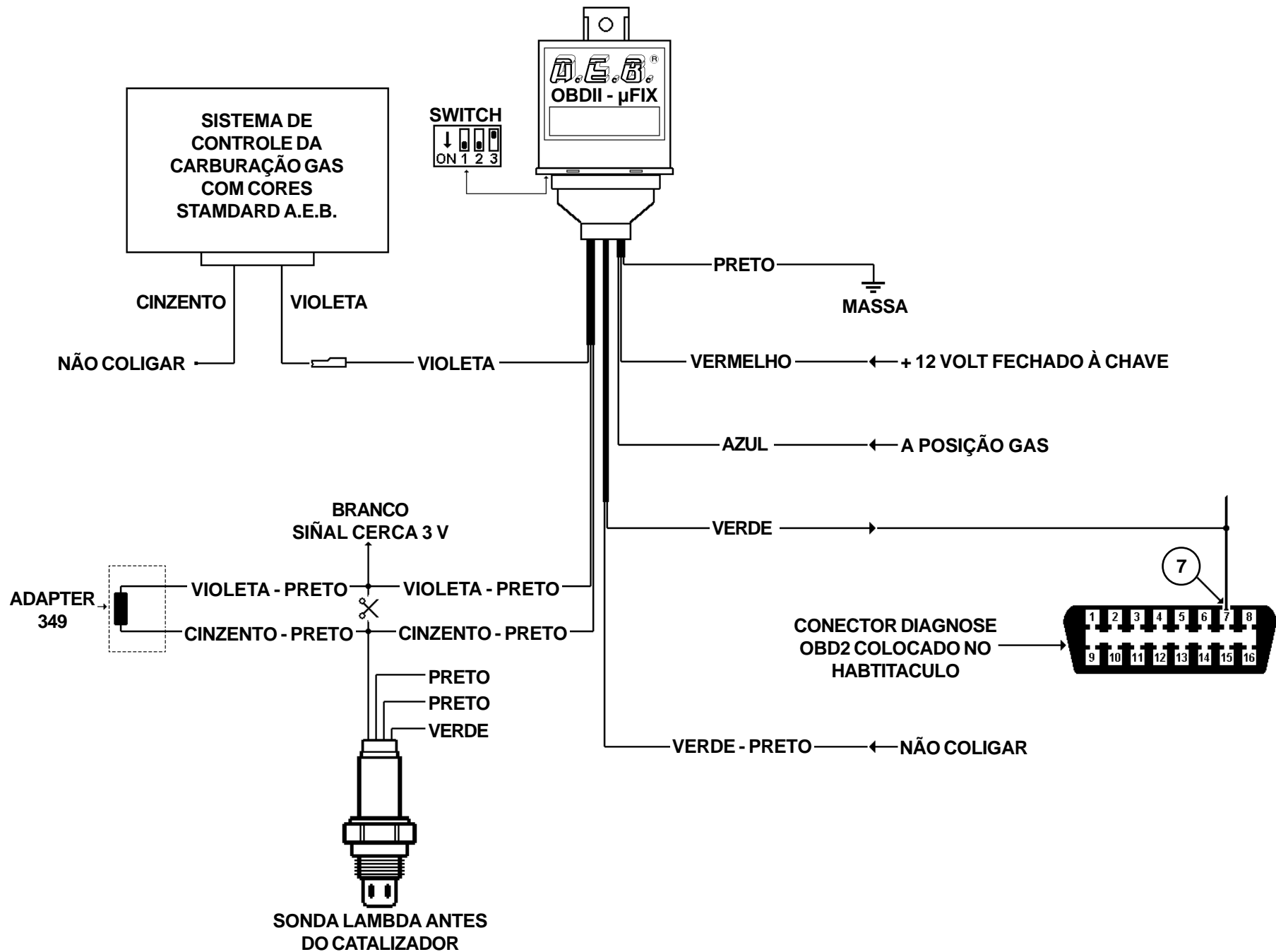

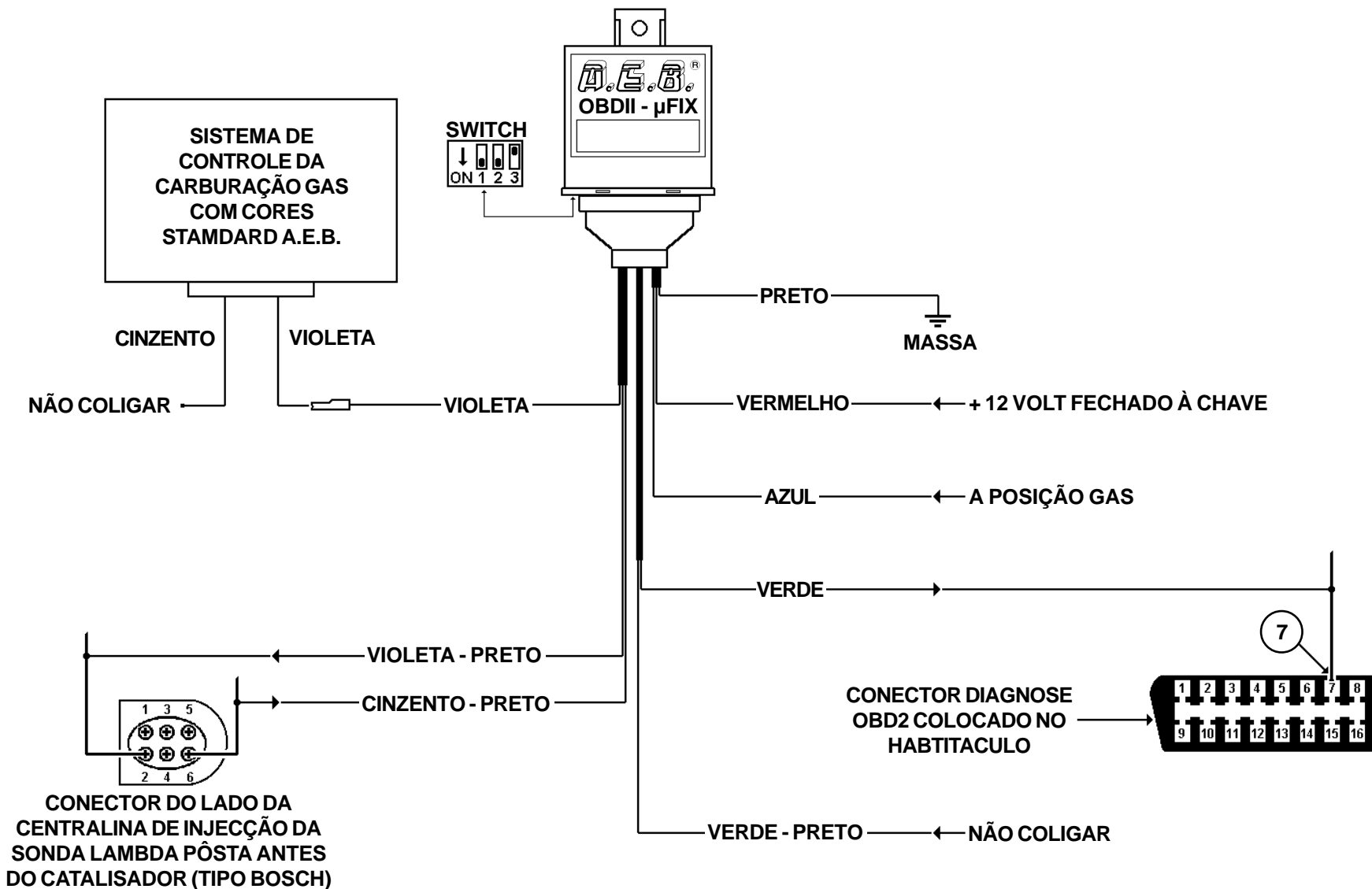

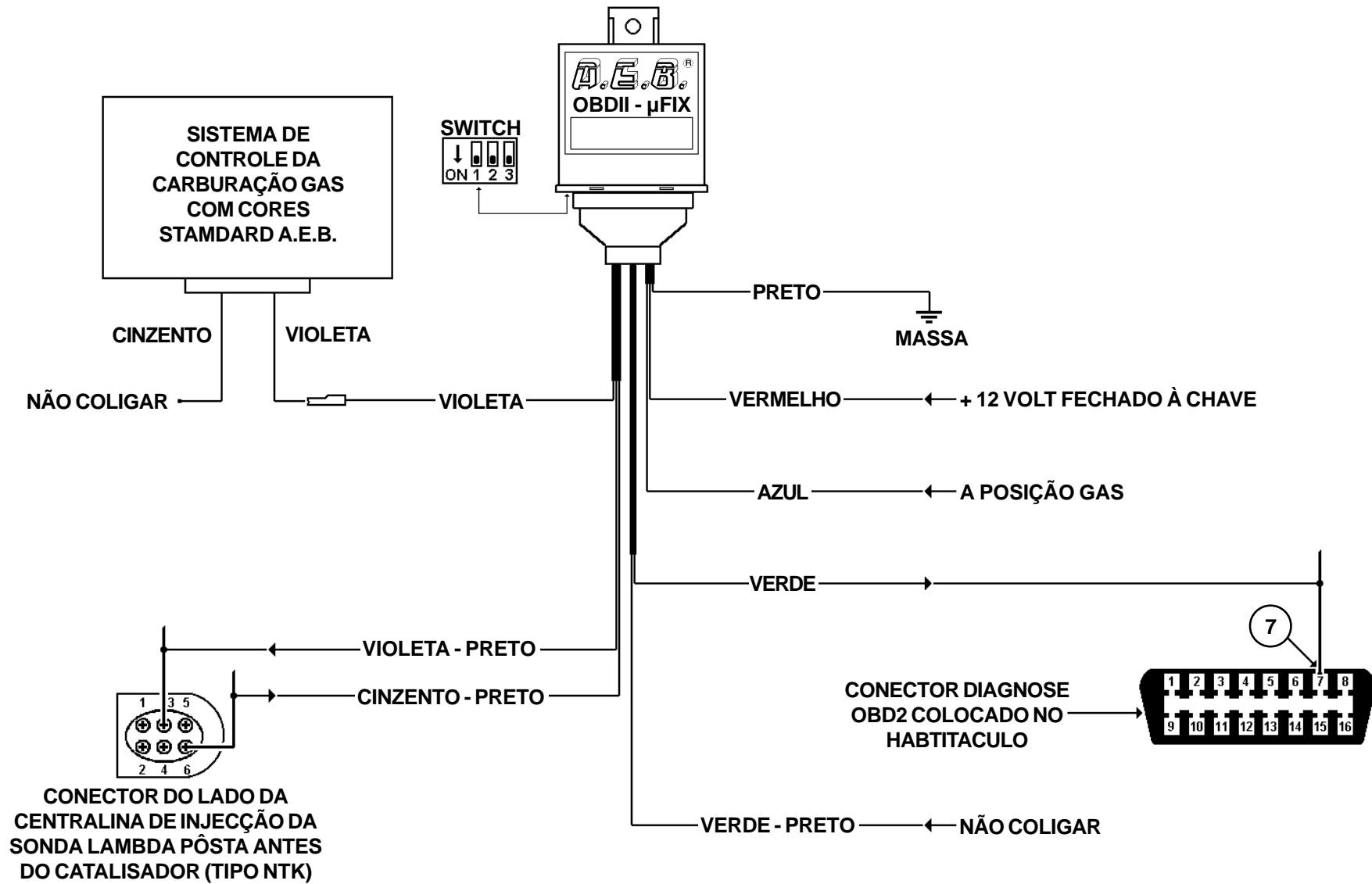

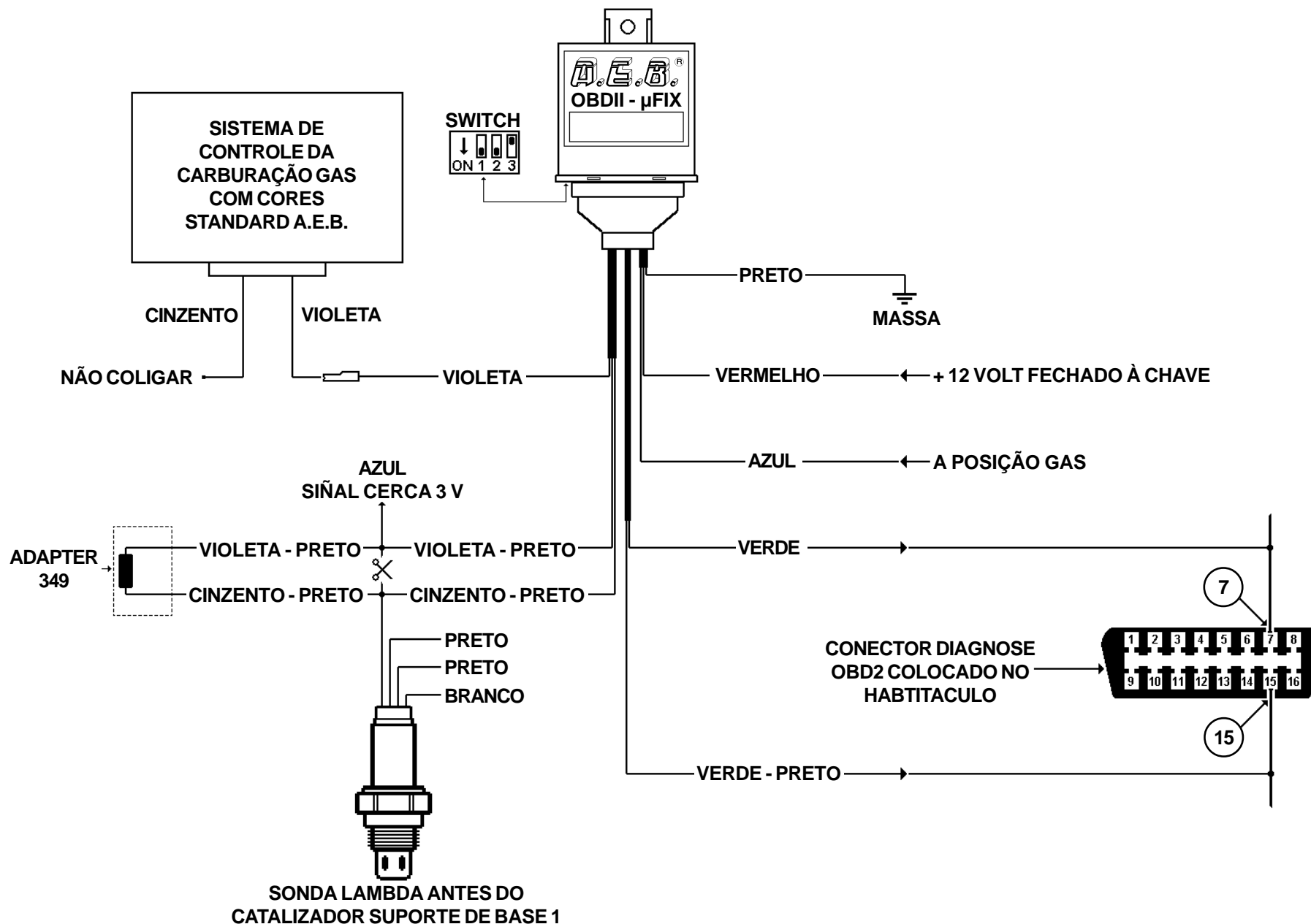

NOTA: A SUPORTE DE BASE 1 ESTÁ EM CORRESPONDÊNCIA DO CILINDRO 1

